

# Stream Digital



The simplest technology  
for continuous capacity  
modulation



# Modulation

There is a common goal shared by many in refrigeration: Preserve and display food at safe temperatures and reasonable operating cost. Varying the capacity available to meet the load is the most significant way to achieve this objective. This ability leads to a more stable temperature in the refrigerated areas and does so at favorable power consumption rates as the production of excessive capacity is avoided.

## Innovative technology

Digital technology is used in Copeland Scroll™ compressors installed in many refrigeration applications worldwide and has proven to be the simplest and most reliable means of continuous capacity modulation. Digital technology is available on Stream 4 and 6 cylinder semi-hermetic reciprocating compressors as well as on Discus Digital 3 cylinder.

## Stream Digital compressors

### Simplicity

Emerson offers Digital modulation as the most simple and precise method of capacity control. A solenoid valve is fitted on the cylinder head of the compressor and actuates a piston that controls the flow of gas into the suction area of the Stream valve plate. When cooling capacity is required and during the normal compression process, refrigerant flows through the valve plate, past the suction reed, and into the compression cylinders.

While in the cylinders, the gas is compressed to a higher pressure before being discharged past the valve and into the

head. This is the “loaded state”. When no cooling capacity is required, the piston interrupts the refrigerant flow into the cylinders, and no compression takes place. This is the “unloaded state”.

This approach to capacity control is simple and the technology is easy to integrate into equipment design and extremely reliable.

### Efficiency, precise pressure and temperature control

The cooling capacity is controlled by modulating the power supply to the solenoid valve fitted on the cylinder head over a cycle time. The capacity output can thereby be infinitely adjusted from 50 to 100% on 4 cylinder and 33% to 100% on 6 cylinder compressors. This broad band of stepless capacity modulation allows a perfect match of capacity and power to the refrigeration load as well as a precise suction pressure control with the associated energy savings.

As a result, stable temperatures in the display cases ensure food quality and freshness under all conditions.

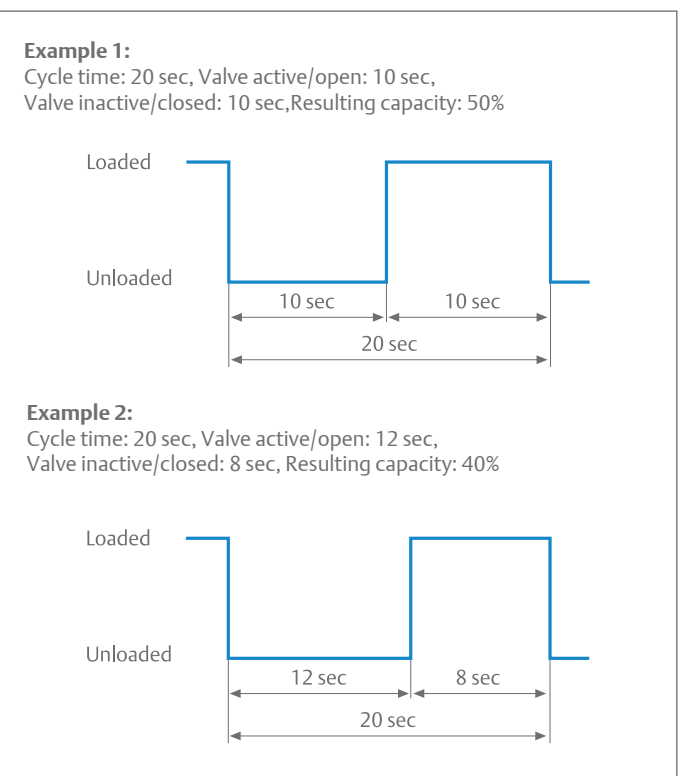
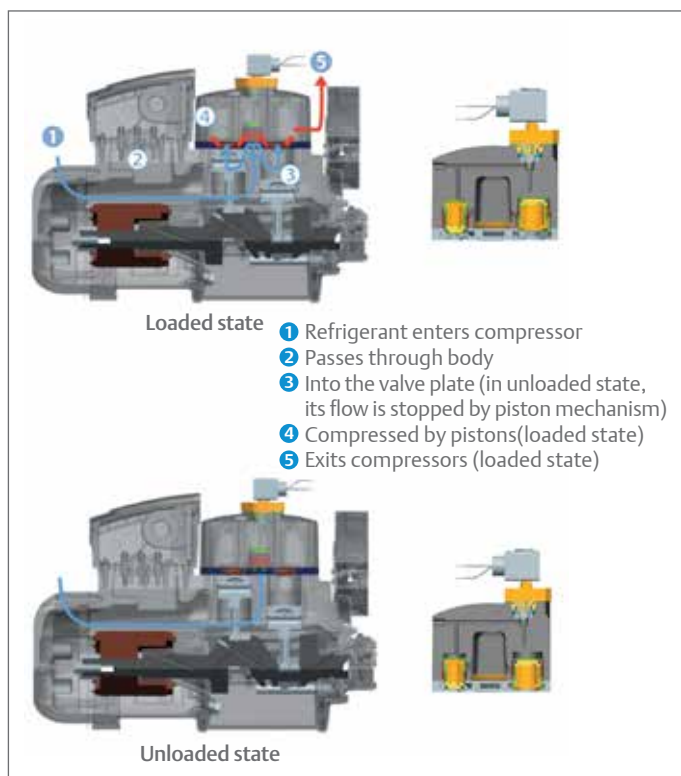

## Reliability

Stream Digital operates at the same rotating speed as a standard compressor. This is beneficial in terms of compressor lubrication compared with modulations that tend to throw more oil in the system at high speeds and where oil return is more problematic at low speeds.

In addition, the design and technical challenges associated with inverter modulation in terms of vibrations or mechanical stress on system piping and compressor parts are therefore avoided. Digital modulation leads to reduced compressor cycling and therefore longer contactor and compressor life.

## Main benefits of Stream Digital

- Broad continuous modulation range for a perfect match of capacity and power to refrigeration load
- Economical and reliable alternative to inverters
- Multi-refrigerant compressor - R407A/F, R448A, R449A, R404A, R134a, R450A, R513A and R407C
- Quick and easy to integrate into equipment
- Simple system and control architecture whatever the compressor size
- Possibility to easily retrofit existing installations with Digital cylinder head kits
- Precise suction pressure/ temperature control with associated energy savings
- Ability to run the system at a higher set point due to elimination of over/under shooting of suction pressure
- Longer refrigeration equipment life time due to reduced compressor cycling
- Individual compressor power consumption monitoring to stay on top of energy costs
- CoreSense™ Diagnostics technology providing advanced protection, diagnostics and preventive maintenance
- Discharge temperature protection
- Possibility to use the Stream sound shell to allow 10 to 13 dBA attenuation for applications in noise sensitive areas

## Operating envelopes

The envelopes for the 4MD and 6MD models are outlined below at full capacity and part load condition.

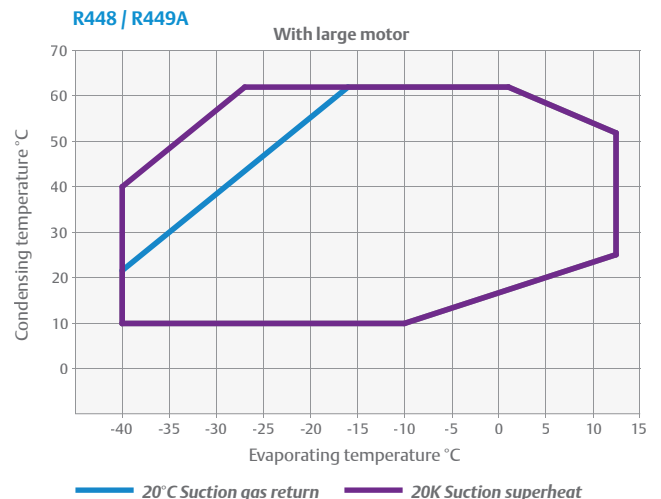
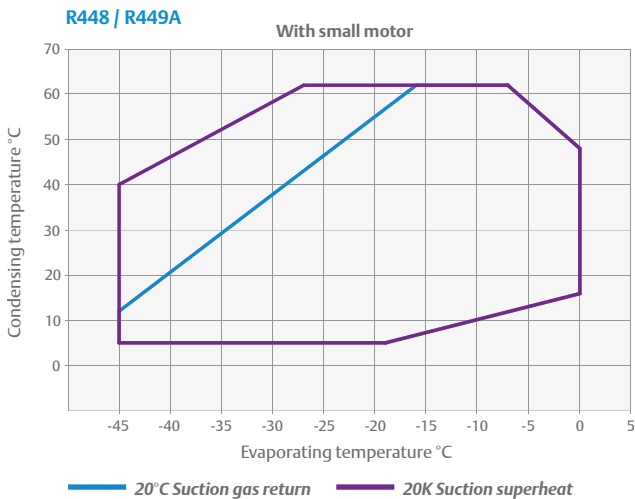
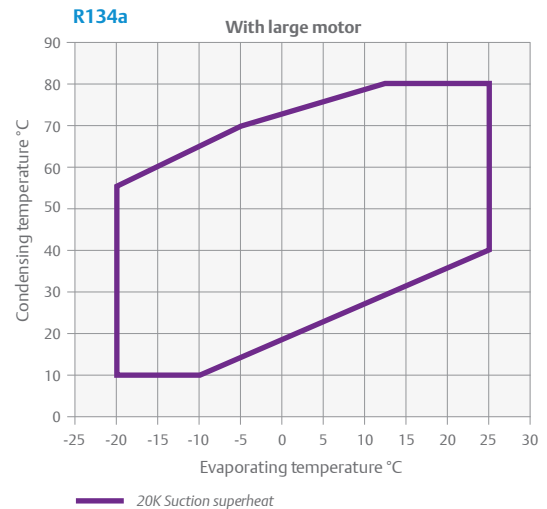
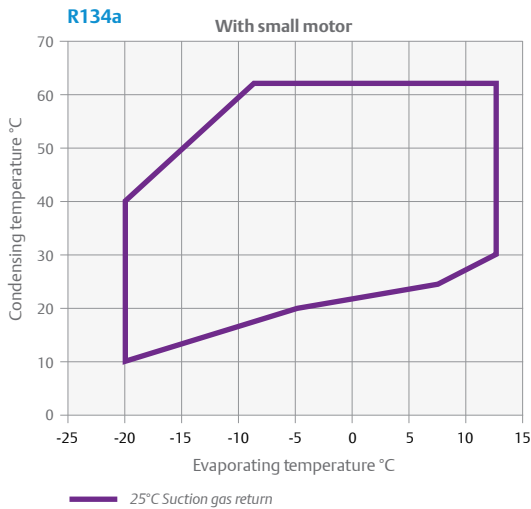



## Technical overview for Stream Digital at full load 100%

Model	Nominal horsepower (hp)	Displacement m <sup>3</sup> /h	Medium temperature						Low temperature		Weight (kg)	Footprint (mm x mm)
			Cooling capacity (kW)			COP			Cooling capacity (kW)	COP		
			R448/R449A*	R134a***	R407A	R448/R449A*	R134a***	R407A				
4MFD-13X	13	62	27.8	18.0	28.8	2.2	2.4	2.3	8.2	1.3	177	381 x 305
4MAD-22X	22	62	31.5	18.7	30.1	2.5	2.4	2.5	7.9	1.3	177	
4MLD-15X	15	71	37.5	21.8	34.9	2.4	2.3	2.4	10.5	1.4	180	
4MHD-25X	25	71	35.9	21.5	35.3	2.4	2.3	2.4	9.5	1.3	187	
4MMD-20X	17	78	39.0	24.1	38.7	2.3	2.3	2.4	11.8	1.4	182	
4MID-30X	27	78	40.6	23.8	38.6	2.5	2.4	2.4	10.8	1.3	188	
4MTD-22X	22	88	44.1	27.4	41.5	2.3	2.3	2.4	13.5	1.4	183	
4MJD-33X	33	88	44.6	26.6	43.4	2.4	2.4	2.2	12.2	1.3	190	
4MUD-25X	25	99	48.9	30.2	47.2	2.3	2.3	2.3	14.4	1.3	186	
4MKD-35X	32	99	50.2	29.8	48.8	2.3	2.3	2.4	13.8	1.3	202	
6MMD-30X	27	120	58.4	36.4	57.5	2.3	2.3	2.4	17.7	1.4	215	
6MID-40X	35	120	61.3	35.0	59.7	2.5	2.3	2.3	17.2	1.3	219	
6MTD-35X	32	135	64.6	41.1	66.0	2.3	2.4	2.4	19.8	1.4	221	
6MJD-45X	40	135	68.4	39.7	66.3	2.4	2.4	2.3	19.6	1.4	223	
6MUD-40X	40	153	75.5	44.9	73.1	2.4	2.3	2.3	22.3	1.4	225	
6MKD-50X	50	153	75.6	42.5	74.0	2.4	2.2	2.4	21.2	1.3	230	

\* Evaporating -10°C, Condensing 45°C, Suction Gas Return 20°C, Subcooling 0K



\*\*\* Evaporating -10°C, Condensing 45°C, Superheat 10K, Subcooling 0K

\*\* Evaporating -35°C, Condensing 40°C, Suction Gas Return 0°C, Subcooling 0K

\*\*\*\* Evaporating -35°C, Condensing 40°C, Superheat 20K, Subcooling 0K

### A complete package: Stream Digital compressor is ready to be controlled by a series of controls

Emerson offers a series of controllers and drivers that can control the Digital compressor in a refrigeration application. All controllers have TCP/IP networking capabilities and web server function.

<p><b>XEV02D</b> - Digital compressor driver. Receives an input signal from an existing system controller (0-10V, 4...20mA) and activates Digital solenoid valve</p>	
<p><b>XC645D*</b> - Controls condensing units including fan speed, using up to a maximum of one 4 cylinder Stream Digital and one 4 cylinder Stream with blocked suction; alternatively one 6 cylinder Stream Digital having blocked suction bank</p>	
<p><b>XC660D* + XEV02D</b> - Controls racks using up to a maximum of one 4 cylinder Stream Digital and two 4 cylinder Stream compressors with blocked suction; alternatively one 6 cylinder Stream Digital with blocked suction and one 6 cylinder Stream with two blocked suctions. Needs to be paired with XEV02D for digital applications.</p>	

\* Each relay is configurable and can operate to manage compressor or blocked suction valve.

[www.EmersonClimate.eu](http://www.EmersonClimate.eu)

**Emerson Commercial & Residential Solutions**

Emerson Climate Technologies GmbH - Pascalstrasse 65 - 52076 Aachen, Germany

Tel. +49 (0) 2408 929 0 - Fax: +49 (0) 2408 929 570 - Internet: [www.emersonclimate.eu](http://www.emersonclimate.eu)

The Emerson logo is a trademark and service mark of Emerson Electric Co. Emerson Climate Technologies Inc. is a subsidiary of Emerson Electric Co. Copeland and Copeland Scroll are trademarks of Emerson Climate Technologies Inc.. All other trademarks are property of their respective owners. Emerson Climate Technologies GmbH shall not be liable for errors in the stated capacities, dimensions, etc., as well as typographic errors. Products, specifications, designs and technical data contained in this document are subject to modification by us without prior notice. Illustrations are not binding. ©2017 Emerson Climate Technologies, Inc.