

# Copeland™ Stream Compressors for R744 Refrigeration

Designed for durability and best-in-class  
performance in CO<sub>2</sub>-transcritical applications



# Designed for Durability and Best-In-Class Performance in CO<sub>2</sub>-Transcritical Applications

Stream series of 4 cylinder CO<sub>2</sub> compressors is the ideal solution for R744 medium temperature cascade and booster systems. It is characterized by a design pressure of 135 bar. Refrigerant flow and heat transfer have been optimized for best performance. All compressors are equipped with CoreSense™ technology and offer the possibility to diagnose system-related problems faster or even before they occur.

The Stream series is the ideal choice for medium temperature transcritical applications as well as for low temperature cascade and booster applications requiring high standstill pressures up to 90 bar suction. The use of transcritical compressors in medium, transcritical side as well as on the low temperature, subcritical side ensures that in case of power outage, the refrigeration system features full resilience and no operation disruption.

## Advanced Features

- Stepless capacity modulation via inverter from 25 to 70 Hz
- Emerson CoreSense Technology

## Features and Benefits

Stream provides flexibility in pack design and operation:

- Compact dimensions
- Integrated high pressure relief valve
- Discharge temperature protection
- Service valve 360° rotation for ease of piping design
- 2 sight glasses for mounting of oil management control and visual inspection
- One additional sight glass for oil visual inspection at run time
- One oil port for oil equalization in parallel system
- Oil splasher system ensuring lubrication at constant and variable speed

## Stream compressor line-up

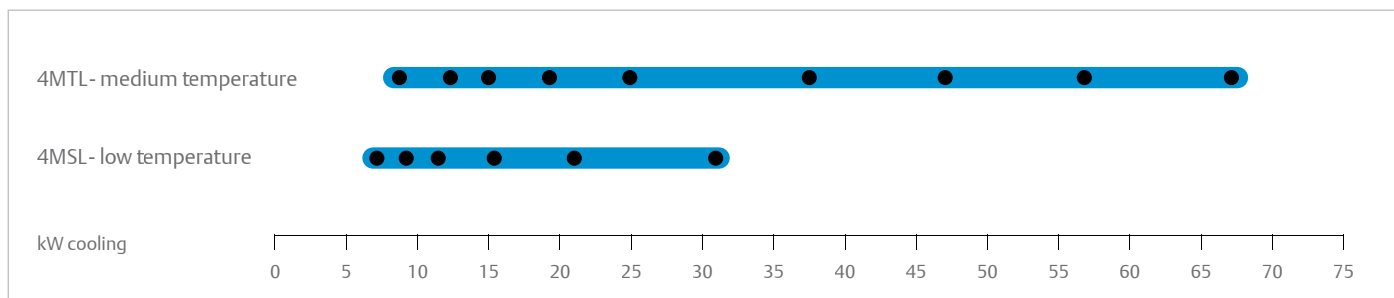

Conditions for 4MTL: EN12900 R744: Evaporating -10°C, Gas cooler exit: 35°C/90 bar, Superheat: 10K for medium temperature  
 Conditions for 4MSL: EN12900 R744: Evaporating -35°C, Condensing -5°C, Superheat 10K, Subcooling 0K for low temperature

## Operating Envelopes

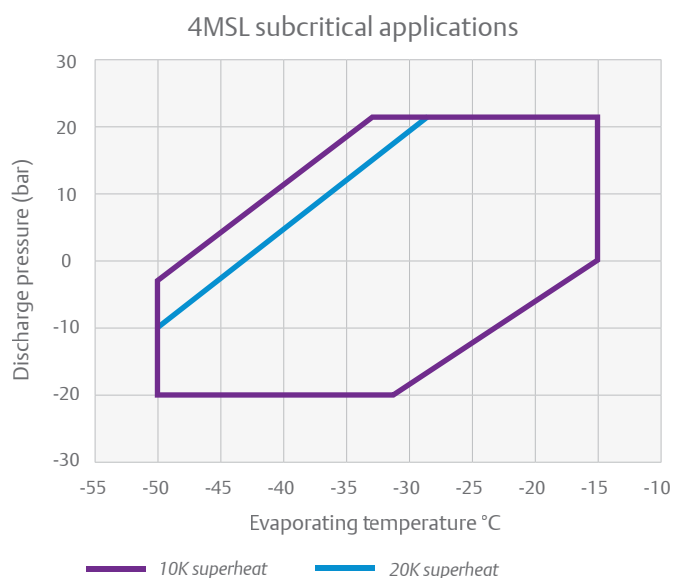
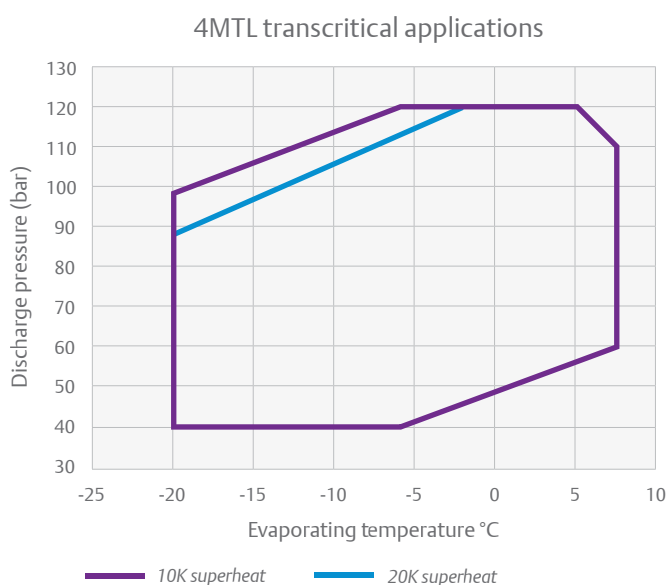

## Dimensions\*

### 4MTL-05X...09X & 4MSL-03X...06X

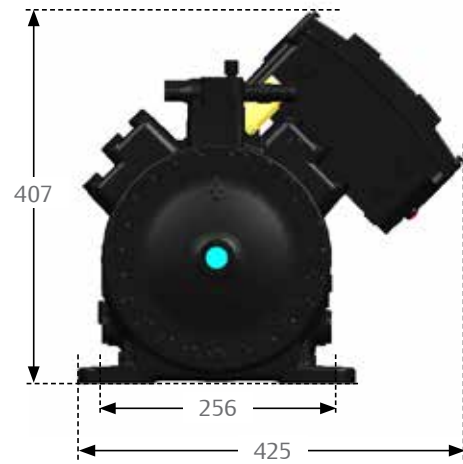
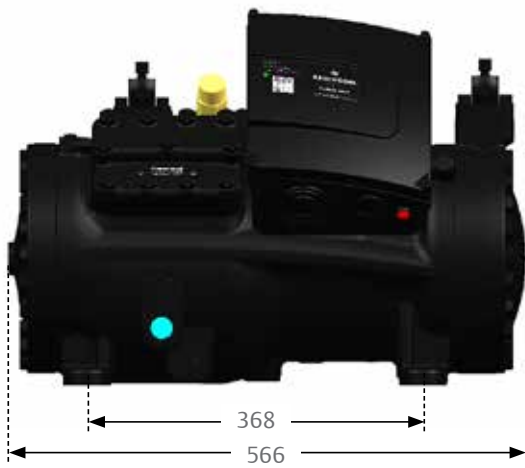

### 4MTL-12X...30X & 4MSL-08X...15X

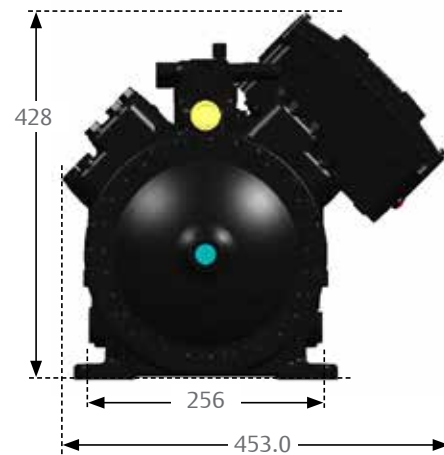
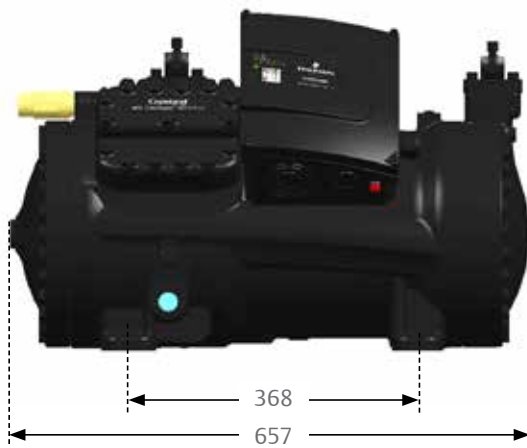

### 4MTL-35X...50X

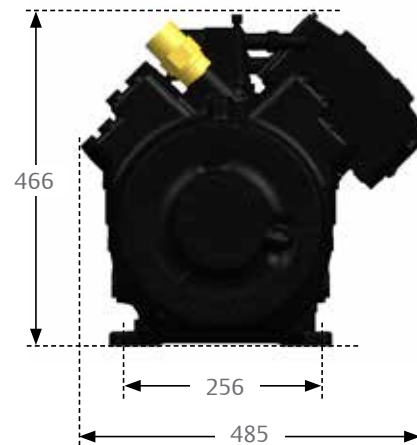
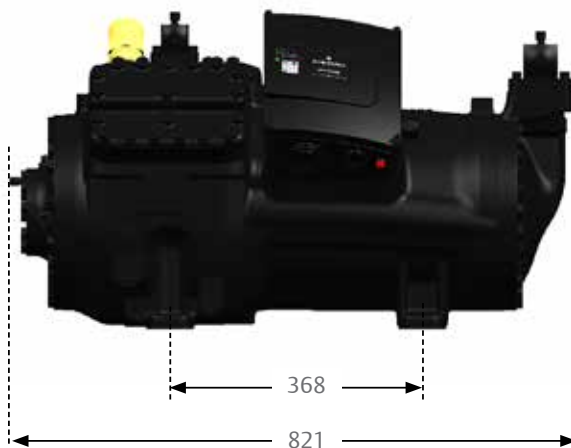

\* Dimensions in mm

## Technical Overview

R744	Nominal horsepower (hp)	Displacement (m <sup>3</sup> /h)	Capacity (kW)	COP	Oil Quantity (l)	Net Weight (kg)	Standstill pressure (high/low side) bar
4MTL-05_	5.0	4.6	8.8	1.62	1.5	123	135/90
4MTL-07_	6.5	6.2	11.8	1.66	1.5	124	
4MTL-09_	9.0	7.4	14.6	1.67	1.5	123	
4MTL-12_	12.0	9.5	19.2	1.70	1.8	170	
4MTL-15_	15.0	12.5	25.2	1.75	1.8	170	
4MTL-30_	30.0	17.9	37.0	1.80	1.8	175	
4MTL-35_	35.0	22.7	45.3	1.79	2.8	264	
4MTL-40_	40.0	26.6	55.9	1.84	2.8	270	
4MTL-50_	50.0	32.0	67.8	1.81	2.8	276	

Conditions: EN12900 R744: Evaporating -10°C, Gas cooler exit: 35°C/90 bar, Superheat: 10K

\*\* 3 Ph: 380-420V/ 50Hz

R744	Nominal horsepower (hp)	Displacement (m <sup>3</sup> /h)	Capacity (kW)	COP	Oil Quantity (l)	Net Weight (kg)	Standstill pressure (high/low side) bar
4MSL-03_	3.0	4.6	7.1	3.33	1.3	120	135/90
4MSL-04_	4.6	6.2	9.7	3.51	1.3	120	
4MSL-06_	6.0	7.4	12.2	3.68	1.3	120	
4MSL-08_	8.0	9.5	15.9	3.60	1.8	170	
4MSL-12_	12.0	12.5	21.0	3.72	1.8	170	
4MSL-15_	15.0	18.0	31.0	3.84	1.8	170	

EN12900 R744 - LT: Evaporating -35°C, Condensing -5°C, Suction Superheat 10K, Subcooling 0K

\*\* 3 Ph: 380-420V/ 50Hz

**For more details, see [climate.emerson.com/en-gb](http://climate.emerson.com/en-gb)**

**Emerson Commercial & Residential Solutions**

Emerson Climate Technologies GmbH - Pascalstrasse 65 - 52076 Aachen, Germany

Tel. +49 (0) 2408 929 0 - Fax: +49 (0) 2408 929 570 - Internet: [climate.emerson.com/en-gb](http://climate.emerson.com/en-gb)

The Emerson logo is a trademark and service mark of Emerson Electric Co. Emerson Climate Technologies Inc. is a subsidiary of Emerson Electric Co. Copeland is a registered trademark and Copeland Scroll is a trademark of Emerson Climate Technologies Inc.. All other trademarks are property of their respective owners. Emerson Climate Technologies GmbH shall not be liable for errors in the stated capacities, dimensions, etc., as well as typographic errors. Products, specifications, designs and technical data contained in this document are subject to modification by us without prior notice. Illustrations are not binding.

© 2020 Emerson Climate Technologies, Inc.

**EMERSON. CONSIDER IT SOLVED.™**