

**Copeland Scroll™**

## Application Guidelines

### Scroll Compressors for Refrigeration

ZB15K\* to ZB220K\*, ZS21K\* to ZS11M\*

ZF06K\* to ZF48K\*, ZF13KVE to ZF48KVE



<b>About these guidelines .....</b>	<b>1</b>
<b>1 Safety instructions .....</b>	<b>1</b>
1.1 Icon explanation .....	1
1.2 Safety statements .....	1
1.3 General instructions .....	2
<b>2 Product description .....</b>	<b>3</b>
2.1 Common information about Copeland Scroll compressors .....	3
2.2 Nomenclature .....	4
2.3 Application range .....	4
2.3.1 <i>Qualified refrigerants and oils</i> .....	4
2.3.2 <i>Application limits</i> .....	5
<b>3 Installation .....</b>	<b>6</b>
3.1 Compressor handling .....	6
3.1.1 <i>Transport and storage</i> .....	6
3.1.2 <i>Positioning and securing</i> .....	6
3.1.3 <i>Installation location</i> .....	6
3.1.4 <i>Mounting parts</i> .....	6
3.2 Brazing procedure .....	7
3.3 Copeland Scroll compressors with liquid injection .....	8
3.3.1 <i>Liquid injection details for ZF06K4E to ZF18K4E compressors</i> .....	8
3.3.2 <i>Current sensing relay</i> .....	9
3.3.3 <i>Liquid injection details for ZF24K4E to ZF48K4E compressors</i> .....	9
3.4 Copeland Scroll compressors with vapour injection .....	10
3.5 Shut-off valves and adaptors .....	11
3.6 Suction accumulators .....	11
3.7 Screens .....	12
3.8 Mufflers .....	12
3.9 Suction line noise and vibration .....	12
<b>4 Electrical connection .....</b>	<b>14</b>
4.1 General recommendations .....	14
4.2 Electrical installation .....	14
4.2.1 <i>Terminal box</i> .....	17
4.2.2 <i>Motor windings</i> .....	17
4.2.3 <i>Protection devices</i> .....	18
4.2.4 <i>Crankcase heaters</i> .....	18
4.3 Pressure safety controls .....	18
4.3.1 <i>High-pressure control</i> .....	18
4.3.2 <i>Low-pressure control</i> .....	18
4.3.3 <i>Internal pressure relief valve</i> .....	18
4.4 Discharge temperature protection .....	19

# Copeland Scroll™

4.5	Motor protection .....	19
4.6	Phase protection .....	20
4.7	Protector functional check and failure detection .....	20
4.7.1	<i>Checking the connection</i> .....	20
4.7.2	<i>Checking the compressor thermistor chain</i> .....	20
4.7.3	<i>Checking the protection module</i> .....	21
4.8	High-potential testing .....	21
<b>5</b>	<b>Starting up &amp; operation</b> .....	<b>22</b>
5.1	Strength pressure test .....	22
5.2	Tightness/pressure test .....	22
5.3	System evacuation .....	22
5.4	Preliminary checks – Pre-starting .....	23
5.5	Charging procedure .....	23
5.6	Initial start-up .....	23
5.7	Rotation direction .....	23
5.8	Starting sound .....	24
5.9	Deep vacuum operation .....	24
5.10	Shell temperature .....	24
5.11	Pump-down cycle .....	24
5.12	Minimum run time .....	25
5.13	Shut-off sound .....	25
5.14	Frequency .....	25
5.15	Oil level .....	25
<b>6</b>	<b>Maintenance &amp; repair</b> .....	<b>26</b>
6.1	Exchanging the refrigerant .....	26
6.2	Rotalock valves .....	26
6.3	Replacing a compressor .....	26
6.3.1	<i>Compressor replacement</i> .....	26
6.3.2	<i>Start-up of a new or replacement compressor</i> .....	26
6.4	Lubrication and oil removal .....	27
6.5	Oil additives .....	27
6.6	Unbrazing system components .....	27
<b>7</b>	<b>Dismantling &amp; disposal</b> .....	<b>28</b>
	<b>DISCLAIMER</b> .....	<b>28</b>

## About these guidelines

The purpose of these application guidelines is to provide guidance in the application of Copeland Scroll™ compressors in users' systems. They are intended to answer the questions raised while designing, assembling and operating a system with these products.

Besides the support they provide, the instructions listed herein are also critical for the proper and safe functioning of the compressors. Emerson Climate Technologies will not guarantee the performance and reliability of the product if it is misused in regard of these guidelines.

These application guidelines cover stationary applications only. For mobile applications, contact Application Engineering as other considerations may apply.

## 1 Safety instructions







Copeland Scroll™ compressors are manufactured according to the latest European and US Safety Standards. Particular emphasis has been placed on the user's safety.

These compressors are intended for installation in systems according to the EC Machinery Directive MD 2006/42/EC and to the Pressure Equipment Directive PED 97/23/EC. They may be put to service only if they have been installed in these systems according to instructions and conform to the corresponding provisions of legislation. For relevant standards please refer to Manufacturers Declaration, available at [www.emersonclimate.eu](http://www.emersonclimate.eu).

These instructions should be retained throughout the lifetime of the compressor.

**You are strongly advised to follow these safety instructions.**

### 1.1 Icon explanation

 <p><b>WARNING</b> This icon indicates instructions to avoid personal injury and material damage.</p>	 <p><b>CAUTION</b> This icon indicates instructions to avoid property damage and possible personal injury.</p>
 <p><b>High voltage</b> This icon indicates operations with a danger of electric shock.</p>	 <p><b>IMPORTANT</b> This icon indicates instructions to avoid malfunction of the compressor.</p>
 <p><b>Danger of burning or frostbite</b> This icon indicates operations with a danger of burning or frostbite.</p>	<p><b>NOTE</b> This word indicates a recommendation for easier operation.</p>
 <p><b>Explosion hazard</b> This icon indicates operations with a danger of explosion.</p>	

### 1.2 Safety statements

- Refrigeration compressors must be employed only for their intended use.
- Only qualified and authorized HVAC or refrigeration personnel are permitted to install, commission and maintain this equipment.
- Electrical connections must be made by qualified electrical personnel.
- All valid standards for connecting electrical and refrigeration equipment must be observed.
- The national legislation and regulations regarding personnel protection must be observed.



**Use personal safety equipment.** Safety goggles, gloves, protective clothing, safety boots and hard hats should be worn where necessary.

# Copeland Scroll™

## 1.3 General instructions



### WARNING

**System breakdown! Personal injuries!** Never install a system in the field and leave it unattended when it has no charge, a holding charge, or with the service valves closed without electrically locking out the system.

**System breakdown! Personal injuries!** Only approved refrigerants and refrigeration oils must be used.



### WARNING

**High shell temperature! Burning!** Do not touch the compressor until it has cooled down. Ensure that other materials in the area of the compressor do not get in touch with it. Lock and mark accessible sections.



### CAUTION

**Overheating! Bearing damage!** Do not operate compressors without refrigerant charge or without being connected to the system.



### CAUTION

**Contact with POE! Material damage!** POE lubricant must be handled carefully and the proper protective equipment (gloves, eye protection, etc.) must be used at all times. POE must not come into contact with any surface or material that it might damage, including without limitation, certain polymers, eg, PVC/CPVC and polycarbonate.



### IMPORTANT

**Transit damage! Compressor malfunction!** Use original packaging. Avoid collisions and tilting.

## 2 Product description

### 2.1 Common information about Copeland Scroll compressors

The Scroll compressor has been under development at Emerson Climate Technologies since 1979. It is the most efficient and durable compressor Emerson Climate Technologies has ever developed for air-conditioning and refrigeration.

These application guidelines deal with all vertical single Copeland Scroll compressors for refrigeration applications from ZB15K\* to ZB220K\*, ZS21K\* to ZS11M\* and ZF06K\* to ZF48K\*, including vapour injection compressors.

Compressor	Cooling capacity kW *							Motor
	R404A*	R407A	R407F*	R448A R449A	R134A	R450A	R513A	
ZB15KCE	3.32	3.22	3.03		2.07	1.73	1.94	PFJ/TFD
ZB19KCE	4.16	3.95	3.80		1.39	2.04	2.36	PFJ/TFD
ZB21KCE	5.05	4.71	4.61		3.01	2.65	3.05	PFJ/TFD
ZB26KCE	5.85	5.43	5.33		3.48	3.06	3.43	PFJ/TFD
ZB29KCE	6.97		6.08			3.48	3.89	PFJ/TFD
ZB30KCE	6.87	6.40	6.61	6.67	4.08	3.60	4.03	PFJ/TFD
ZB38KCE	8.53	8.32	8.21	8.34	5.07	4.47	5.03	PFJ/TFD
ZB45KCE	10.05	9.49	9.66	9.76	6.04	5.26	5.92	TFD
ZB48KCE	11.63		10.79	11.22		5.89	6.59	TFD
ZB56KCE	11.75							TWD
ZB57KCE	13.22		12.84					TFD
ZB75KCE	17.15							TWD
ZB92KCE	21.20							TWD
ZB11MCE	25.80							TWD

Table 1: Cooling capacity for medium temperature compressors @EN 12900 Medium temperature

Compressor	Cooling capacity kW **					Motor
	R404A*	R407A*	R407F*	R448A R449A	R134A	
ZF06K4E	1.43		3.43	1.29		TFD
ZF08K4E	1.76		4.36	1.59		TFD
ZF09K4E	1.94	4.97	4.75	1.75		TFD
ZF11K4E	2.46	5.78	5.93	2.22		TFD
ZF13K4E	2.78	6.25	7.03	2.51	4.39	TFD
ZF15K4E	3.42	7.75	8.46	3.08	5.34	TFD
ZF18K4E	4.18	9.24	10.30	3.65	6.30	TFD
ZF24K4E	5.16				7.75	TWD
ZF33K4E	7.09				10.95	TWD
ZF40K4E	8.78					TWD
ZF48K4E	10.60					TWD
ZF13KVE	3.96	8.48	3.30	3.27		TFD
ZF18KVE	5.91	12.95	4.92	4.55		TFD
ZF24KVE	7.20					TWD
ZF33KVE	9.80					TWD
ZF40KVE	11.92					TWD
ZF48KVE	14.92					TWD

Table 2: Cooling capacity for medium temperature compressors @EN 12900 Low temperature

# Copeland Scroll™

## \* EN 12900 Conditions for medium temperature:

Evaporating temperature .....-10°C      Suction gas return temperature.....20°C  
 Condensing temperature ..... 45°C      Liquid sub-cooling ..... 0K

## \*\* EN 12900 Conditions for low temperature:

Evaporating temperature .....-35°C      Suction gas return temperature.....20°C  
 Condensing temperature ..... 40°C      Liquid sub-cooling ..... 0K

These compressors have one Scroll compression set driven by a single or three-phase induction motor. The Scroll set is mounted at the upper end of the rotor shaft of the motor. The rotor shaft axis is in the vertical plane.

## 2.2 Nomenclature

The model designation contains the following technical information about the standard and vapour injection compressors:

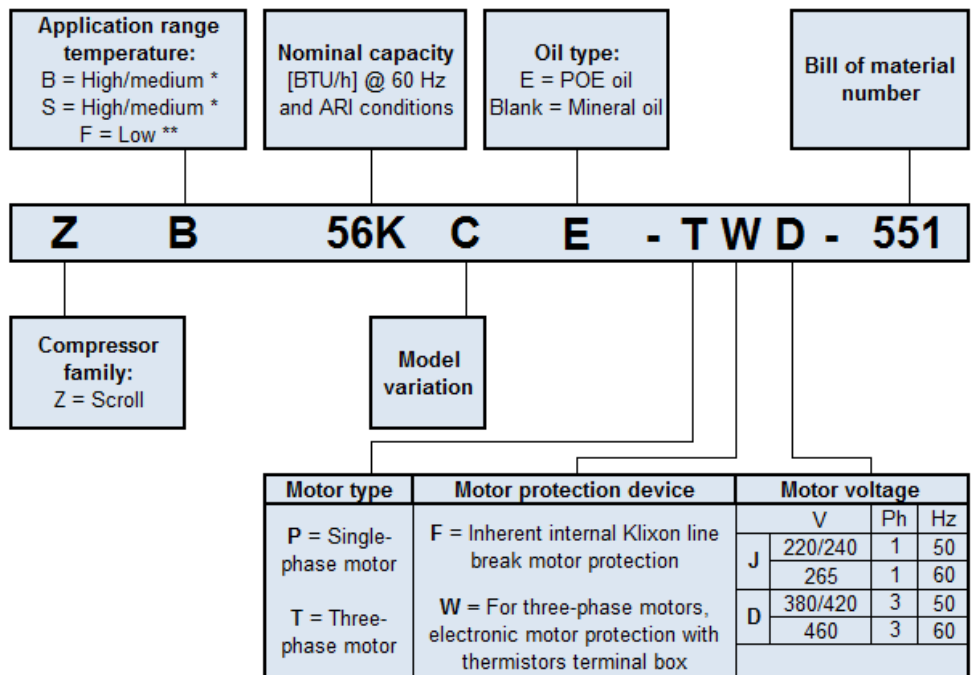

## 2.3 Application range

### 2.3.1 Qualified refrigerants and oils



#### WARNING

#### Use of R450A and R513A refrigerants! Risk of compressor damage!

Refrigerant migration of R450A or R513A into the compressor crankcase could cause low oil viscosity, which could lead to compressor damage. When using R450A and R513A it is critical to meet the following requirements:

- maintain adequate superheat settings with a minimum superheat of 8-10K;
- no liquid refrigerant migration into the compressor at any time, especially during standstill, during or after defrost, or after reverse mode for example in heat pumps;
- pumpdown is recommended;
- the use of a crankcase heater is mandatory;
- retrofit to R450A and R513A is only allowed for compressors which are approved for these refrigerants.

Contact Application Engineering for any further information.



#### IMPORTANT

It is essential that the glide of refrigerant blends (primarily R407C and R407F) be carefully considered when adjusting pressure and superheat controls.

Oil recharge values can be taken from Copeland Scroll compressors brochures or Copeland™ brand products Select software.

Compressor	ZB	ZS, ZF	ZF*KVE
Qualified refrigerants	R404A, R407C, R407A <sup>1)</sup> , R407F <sup>1)</sup> , R448A, R449A, R134a, R22	R404A, R407A <sup>1)</sup> , R407F <sup>1)</sup> , R134a, R448A, R449A, R450A, R513A, R22	R404A, R407A <sup>1)</sup> , R407F <sup>1)</sup>
Copeland brand products standard oil	Emkarate RL 32 3MAF		
Servicing oils	Emkarate RL 32 3MAF, Mobil EAL Arctic 22 CC		

<sup>1)</sup> Only valid for models ZB30K\* to ZB48K\*, ZB57K\*, ZF06K4E to ZF18K4E and ZF13KVE to ZF18KVE

Table 3: Qualified refrigerants and oils

### 2.3.2 Application limits



#### CAUTION

**Inadequate lubrication! Compressor breakdown!** The superheat at the compressor suction inlet must always be sufficient to ensure that no refrigerant droplets enter the compressor. For a typical evaporator-expansion valve configuration a minimum stable superheat of at least 5K is required.

Application envelopes for the various refrigerants can be found in Select software, available at [www.emersonclimate.eu](http://www.emersonclimate.eu).

## 3 Installation



### WARNING

**High pressure! Injury to skin and eyes possible!** Be careful when opening connections on a pressurized item.

### 3.1 Compressor handling

#### 3.1.1 Transport and storage



### WARNING

**Risk of collapse! Personal injuries!** Move compressors only with appropriate mechanical or handling equipment according to weight. Keep in the upright position. Stack pallets on top of each other when not exceeding 300 kg. Do not stack single boxes on top of each other. Keep the packaging dry at all times.

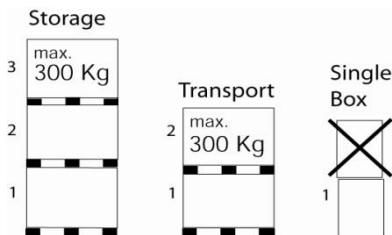

Figure 1: Transport and storage

#### 3.1.2 Positioning and securing



### IMPORTANT

**Handling damage! Compressor malfunction!** Only use the lifting eyes whenever the compressor requires positioning. Using discharge or suction connections for lifting may cause damage or leaks.

If possible, the compressor should be kept vertical during handling. The discharge connection plug should be removed first before pulling the suction connection plug to allow the dry air pressure inside the compressor to escape. Pulling the plugs in this sequence prevents oil mist from coating the suction tube making brazing difficult. The copper-coated steel suction tube should be cleaned before brazing. No object, eg, a swaging tool should be inserted deeper than 51 mm into the suction tube or it might damage the suction screen and motor.

#### 3.1.3 Installation location

Ensure the compressors are installed on a solid level base.

#### 3.1.4 Mounting parts

Four vibration absorber grommets are supplied with each compressor. They dampen the start-up surge of the compressor and minimise sound and vibration transmission to the compressor base during operation. The metal sleeve inside is a guide designed to hold the grommet in place. It is not designed as a load-bearing member, and application of excessive torque to the bolts can crush the sleeve. Its inner diameter is approximately 8.5 mm to fit, eg, an M8 screw. The mounting torque should be  $13 \pm 1$  Nm. It is critically important for the grommet not to be compressed.

If the compressors are mounted in tandem or used in parallel, then the hard mountings (bolt M9 5/16") are recommended. The mounting torque should be  $27 \pm 1$  Nm. It is possible to deliver these hard mounting parts as a kit, or on request to deliver the compressor with these parts instead of the rubber grommets.

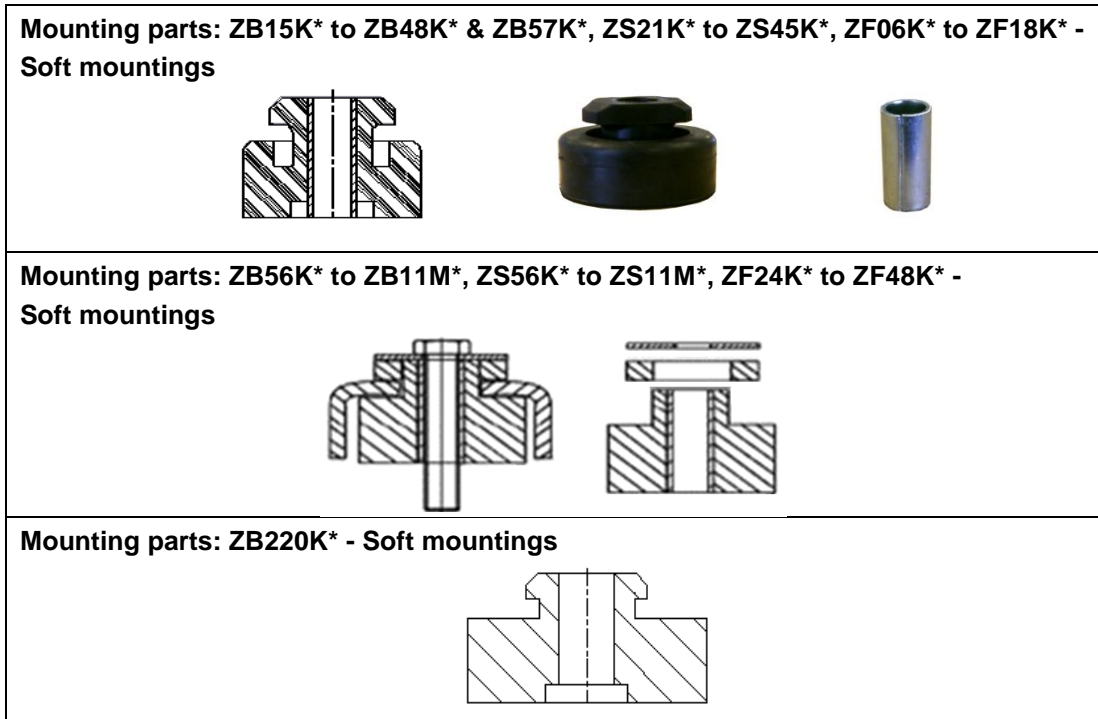

Figure 2: Mounting parts

## 3.2 Brazing procedure

### IMPORTANT

**Blockage! Compressor breakdown!** Maintain a flow of oxygen-free nitrogen through the system at very low pressure during brazing. Nitrogen displaces the air and prevents the formation of copper oxides in the system. If allowed to form, the copper oxide material can later be swept through the system and block screens such as those protecting capillary tubes, thermal expansion valves, and accumulator oil return holes.

**Contamination or moisture! Bearing failure!** Do not remove the plugs until the compressor is set into the unit. This minimises any entry of contaminants and moisture.

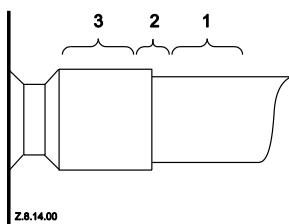

Figure 3: Suction tube brazing areas

Copeland Scroll compressors have copper-plated steel suction and discharge tubes. These tubes are far more robust and less prone to leaks than copper tubes. Due to the different thermal properties of steel and copper, brazing procedures may have to be changed from those commonly used.

Refer to **Figure 3** and the procedure below for the brazing of the suction and discharge lines to a scroll compressor.

- The copper-coated steel tubes on Scroll compressors can be brazed in approximately the same manner as any copper tube.
- Recommended brazing materials: any silfos material is recommended, preferably with a minimum of 5% silver. However, 0% silver is acceptable.
- Be sure tube fitting inner diameter and tube outer diameter are clean prior to assembly.
- Using a double-tipped torch, apply heat in area 1.
- As the tube approaches brazing temperature, move the torch flame to area 2.
- Heat area 2 until braze temperature is attained, moving the torch up and down and rotating around the tube as necessary to heat the tube evenly. Add braze material to the joint while moving the torch around the joint to flow braze material around the circumference.
- After the braze material flows around the joint, move the torch to heat area 3. This will draw the braze material down into the joint. The time spent heating area 3 should be minimal.
- As with any brazed joint, overheating may be detrimental to the final result.

# Copeland Scroll™

## To disconnect:

- Heat joint areas 2 and 3 slowly and uniformly until the braze material softens and the tube can be pulled out of the fitting.

## To reconnect:

- Recommended brazing materials: Silfos with minimum 5% silver or silver braze used on other compressors. Due to the different thermal properties of steel and copper, brazing procedures may have to be changed from those commonly used.

**NOTE:** Since the discharge stub contains a check valve, care must be taken not to overheat it to prevent brazing material from flowing into it.

## 3.3 Copeland Scroll compressors with liquid injection

The installation of liquid injection is mandatory for all ZF\* compressors used in low temperature applications. Liquid injection will keep discharge gas temperatures within safe limits. All corresponding operating envelopes are based on the use of liquid injection.

### 3.3.1 Liquid injection details for ZF06K4E to ZF18K4E compressors

Liquid injection is achieved by means of a Discharge Temperature Control (DTC) valve. The same DTC valve can be used for all compressors and approved refrigerants. For the selection of adequate liquid injection parts such as DTC valve and discharge thermostat, refer to the Emerson Climate Technologies spare parts software at [www.emersonclimate.eu](http://www.emersonclimate.eu).

The ZF compressors include a well in the top cap combined with a valve cap. The Copeland DTC valve is equipped with a custom bulb profile, which must be installed in the top well of the compressor sensing the temperature closest to the discharge port. The bulb/bellows combination injects only when cooling is needed and in the required amounts. The connection to the liquid line is a 3/8" braze.

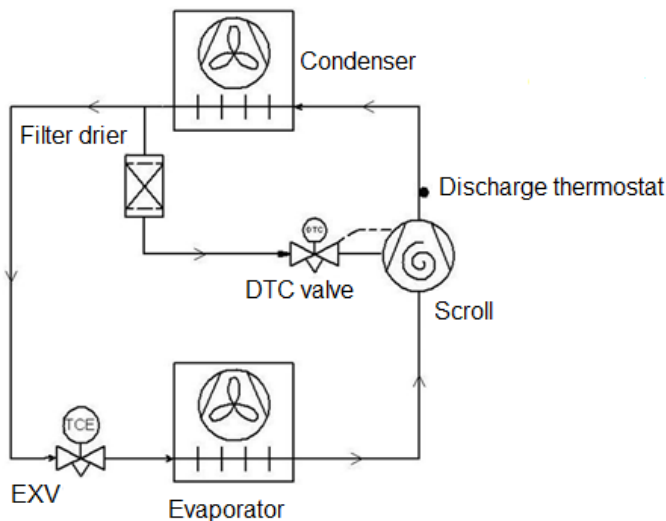

Figure 4: Liquid injection with DTC valve

To prevent a partial or full blockage at the injection port caused through shavings, foreign bodies etc a filter should be installed in the liquid line prior to the DTC valve inlet.

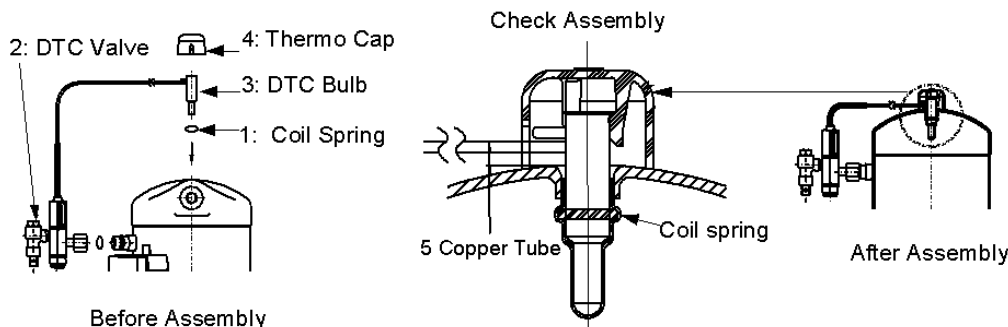

Figure 5: DTC valve assembly

### 3.3.2 Current sensing relay

The current sensing relay only concerns ZF compressors, namely models ZF06K\* to ZF18K\* with liquid injection and models ZF13KVE to ZF18 KVE with vapour injection using capillary tubes.

Power to the injection solenoid must be cut if the internal motor protector trips and the danger of flooding the compressor arises. For models mentioned above a current sensing relay, eg, KRIWAN INT215, Type K35 can be supplied.

The relay must be installed in a way that it senses the same phase as the control circuit it is hooked up to. "L1" in **Figure 6** serves only as an example. It has to be wired in such a way that marking "L" faces the compressor and "K" the contactor.

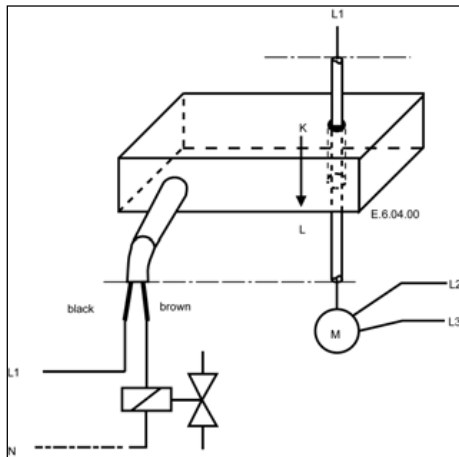

Kriwan INT 215K 35	
Ambient Temperature	-20..... +60°C
Switching Capacity	AC 50/60Hz 115/230 V Max, 0.5A, Cos φ=0.4 12....40VA
Holding Current	L <sub>min</sub> 0.05A
Protection Class	IP 67

Figure 6: Current sensing relay

### 3.3.3 Liquid injection details for ZF24K4E to ZF48K4E compressors

The compressor is supplied with a 1/4" diameter injection stub to accept a capillary tube. Liquid injection takes place directly with the capillary tube as shown in **Figure 7**. Injection takes place into two distinct pockets of the spirals which has no impact on the suction process. Injection increases the mass flow through the condenser.

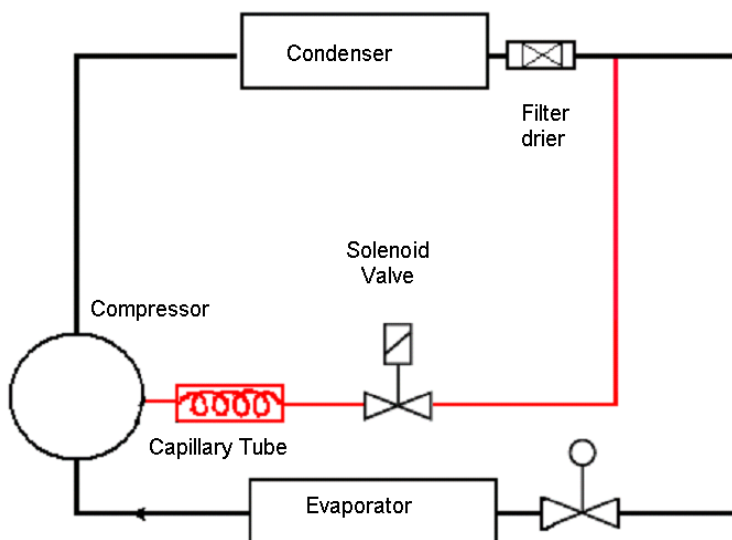

Figure 7: Liqui injection

The capillary tube is needed to meter the correct amount of liquid refrigerant into the compressor. For liquid injection it consists of a wrapped capillary tube inside a shell. It is supplied with a clamp to support the assembly at the injection port. In case this assembly is not desired but an own device has to be built, please take the specifications out of **Table 4**.

# Copeland Scroll™

R404A/R507			R22	
Model	I.D. (inch)	Length (inch)	I.D. (inch)	Length (inch)
ZF24K4E	0.050"	30"	0.050"	5"
ZF33K4E	0.050"	17.5"	0.050"	5"
ZF40K4E	0.070"	30"	0.070"	30"
ZF48K4E	0.070"	30"	0.070"	10"

Table 4: Capillary tube details

A standard On/Off solenoid valve such as Alco 110 RB 2T2 should be used. The valve should have a port diameter of at least 1.4 mm and should be wired to open when the compressor is running and to close:

- when the compressor shuts off;
- during a hot gas defrost;
- during a pump down cycle.

A filter drier such as Alco ADKPlus 036MMS or ADKPlus 032S should be installed before the solenoid valve to avoid blocking the valve and the injection device. If the internal motor protector trips power to the injection solenoid must be shut-off.

### 3.4 Copeland Scroll compressors with vapour injection

The installation of vapour injection is mandatory for all ZF\* compressors used in low temperature applications. All corresponding operating envelopes are based on the use of vapour injection or wet injection.

Copeland Scroll compressors with vapour injection are equipped with a vapour injection connection for Economizer Operation. Economizing can be accomplished by using a subcooling circuit similar to the circuit shown in **Figure 8**. This increases the refrigeration capacity and the system efficiency.

The line diagram shows a system configuration for the economizer cycle. A heat exchanger is used to provide additional subcooling to the refrigerant before it enters the evaporator. This subcooling process provides the increased capacity gain measured in the system.

The refrigerant evaporated through the heat exchanger is injected into the compressors and provides additional cooling at higher compression ratios.

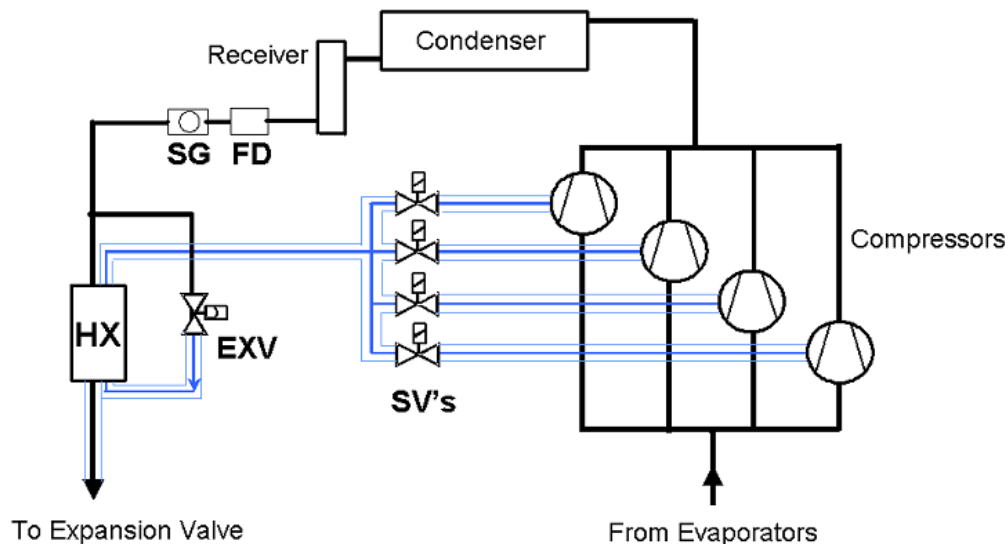

Figure 8: Vapour injection line diagram

**NOTE:** For further information on vapour injection refer to Technical Information C7.19.1 "Vapour Injection Scroll Compressors for Refrigeration" and C7.19.2 "ZF\* Refrigeration Copeland Scroll™ Compressors Using R407A and R407F in Low Temperature Applications".

## 3.5 Shut-off valves and adaptors



### CAUTION

**Leaking system! System breakdown!** It is strongly recommended to periodically re-torque all pipe and fixing connections to the original setting after the system has been put into operation.

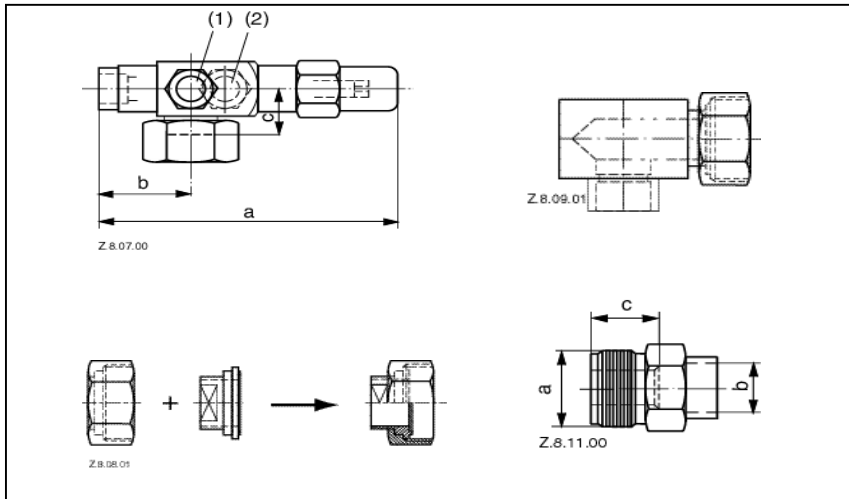

Figure 9

Copeland Scroll compressors are delivered with a discharge check valve fitted inside the discharge port and rubber plugs fitted to the suction and discharge ports as standard. There are options to fit either Rotalock valves, or Rotalock adaptors or just make brazing connections.

Brazing connections can be converted to Rotalock by means of adaptors. Rotalock shut-off valves are available for the suction as well as discharge sides. Using either straight or angled adaptors provides a way to convert a Rotalock into a brazing connection.

Refer to the following table for proper tightening torques:

	Torque [Nm]
Rotalock 3/4" – 16UNF	40-50
Rotalock 1" – 14UNS	70-80
Rotalock 1 1/4" – 12UNF	110-135
Rotalock 1 3/4" – 12UNF	135-160
Rotalock 2 1/4" – 12UNF	165-190

Table 5

**NOTE:** More information about adaptors and shut-off valves can be found in the spare parts software at [www.emersonclimate.eu](http://www.emersonclimate.eu).

## 3.6 Suction accumulators



### CAUTION

**Inadequate lubrication! Bearing destruction!** Minimise liquid refrigerant returning to the compressor. Too much refrigerant dilutes the oil. Liquid refrigerant can wash the oil off the bearings leading to overheating and bearing failure. For R450A and R513A refrigerants Emerson Climate Technologies recommends to use suction accumulators, unless it has been qualified that an accumulator is not needed – see below.

Irrespective of system charge, oil dilution may occur if large amounts of liquid refrigerant repeatedly flood back to the compressor during:

- normal off cycles;
- defrost;
- varying loads.

# Copeland Scroll™

In such a case an accumulator must be used to reduce flood-back to a safe level that the compressor can handle. The use of accumulators is dependent on the application. If an accumulator must be used, the oil-return orifice should be from 1 to 1.4 mm in diameter for models ZB15K\* to ZB48K\*, ZB57K\*, ZS19K\* to ZS45K\*, ZF06K\* to ZF18K\* and 2.0 mm for models ZB56K\* to ZB11M\*, ZS56K\* to ZS11M\*, ZF24K\* to ZF48K\* depending on compressor size and compressor flood-back results.

The size of the accumulator depends upon the operating range of the system and the amount of subcooling and subsequent head pressure allowed by the refrigerant control.

## 3.7 Screens



### CAUTION

**Screen blocking! Compressor breakdown!** Use screens with at least 0.6 mm openings.

The use of screens finer than 30 x 30 mesh (0.6 mm openings) anywhere in the system should be avoided with these compressors. Field experience has shown that finer mesh screens used to protect thermal expansion valves, capillary tubes, or accumulators can become temporarily or permanently plugged with normal system debris and block the flow of either oil or refrigerant to the compressor. Such blockage can result in compressor failure.

## 3.8 Mufflers

External mufflers, normally applied to piston compressors in the past, may not be required for Copeland Scroll compressors.

Individual system tests should be performed to verify acceptability of sound performance. If adequate attenuation is not achieved, use a muffler with a larger cross-sectional area to inlet area ratio. A ratio of 20:1 to 30:1 is recommended.

A hollow shell muffler will work quite well. Locate the muffler at minimum 15 to maximum 45 cm from the compressor for the most effective operation. The further the muffler is placed from the compressor within these ranges, the more effective. Choose a muffler with a length of 10 to 15 cm.

## 3.9 Suction line noise and vibration

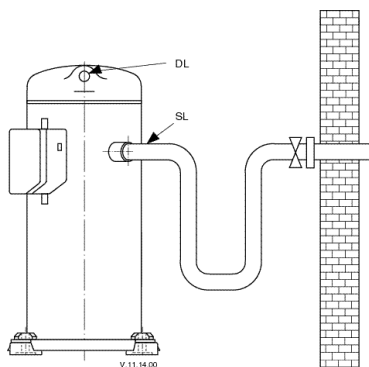

Figure 10: Suction tube design

Copeland Scroll compressors inherently have low sound and vibration characteristics. However in some respects the sound and vibration characteristics differ from reciprocating compressors and in rare instances could result in unexpected sound generation. One difference is that the vibration characteristic of the scroll compressor, although low, includes two very close frequencies, one of which is normally isolated from the shell by the suspension of an internally-suspended compressor. These frequencies, which are present in all compressors, may result in a low-level "beat" frequency that can be detected as noise coming along the suction line into the building under some conditions. Elimination of the beat can be achieved by attenuating either of the contributing

frequencies. This is easily done by using one of the common combinations of recommended design configurations. The scroll compressor makes both a rocking and twisting motion and enough flexibility must be provided in the line to prevent vibration transmission into any lines attached to the unit. In a split system, the most important goal is to ensure minimal vibration in all directions at the service valve to avoid transmitting vibrations to the structure to which the lines are fastened.

A second difference of the Copeland Scroll is that under some conditions the normal rotational starting motion of the compressor can transmit an "impact" noise along the suction line. This may be particularly pronounced in three-phase models due to their inherently higher starting torque. This phenomenon, like the one described previously, also results from the lack of internal

suspension and can be easily avoided by using standard suction line isolation techniques as described below.

## Recommended configuration

- Tubing configuration: .....small shock loop
- Service valve: ..... "angled" valve fastened to unit / wall
- Suction muffler: .....not required

## Alternative configuration

- Tubing configuration: .....small shock loop
- Service valve:..... "straight through" valve fastened to unit / wall
- Suction muffler: .....may be required (acts as dampening mass)

## 4 Electrical connection

### 4.1 General recommendations

The compressor terminal box has a wiring diagram on the inside of its cover. Before connecting the compressor, ensure the supply voltage, the phases and the frequency match the nameplate data.

### 4.2 Electrical installation

Single-phase (PF\*) compressors:

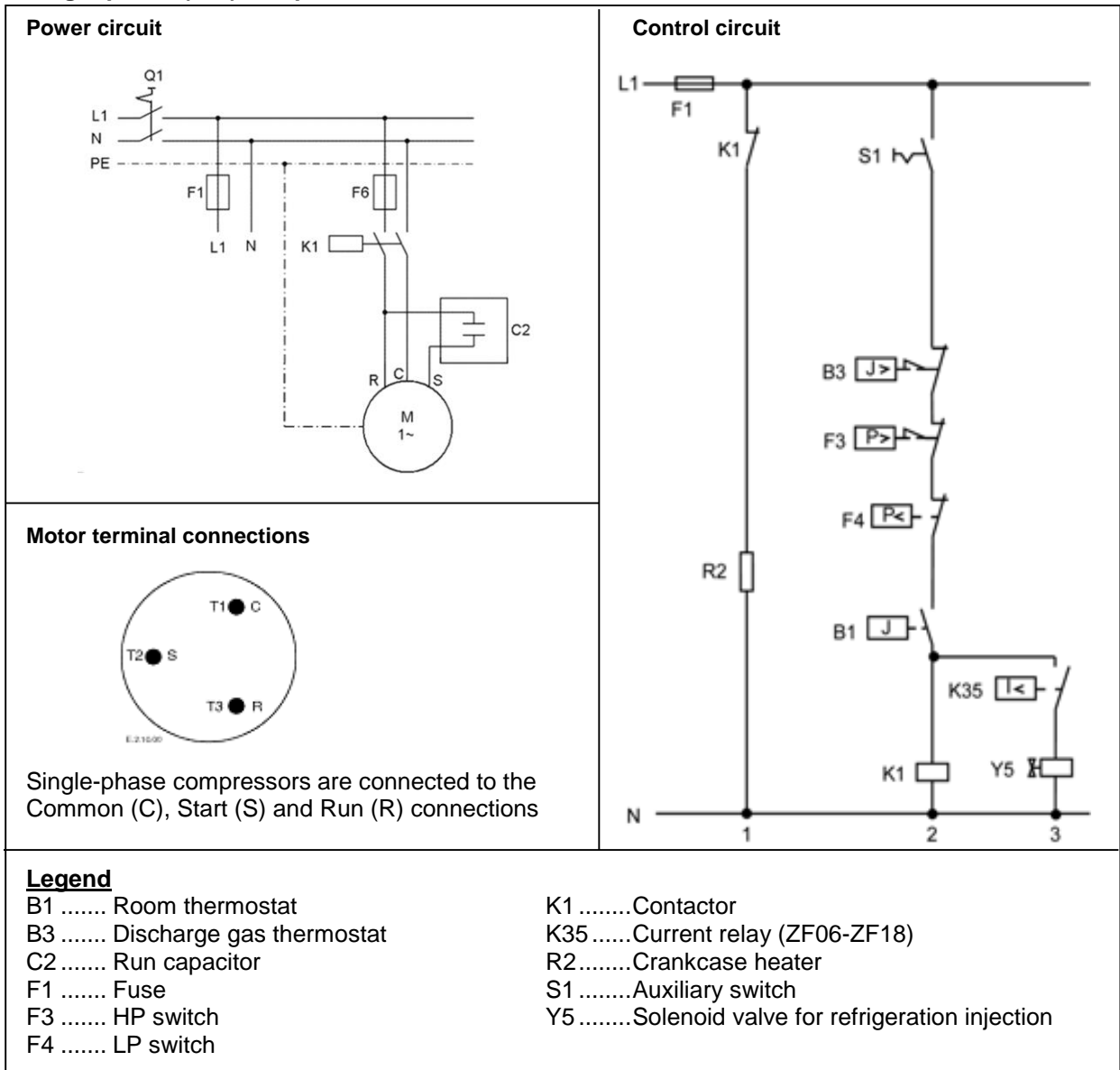

Figure 11

## Three-phase compressors (TF\*) with internal motor protection:

For the ZB15K\* to ZB48K\*, ZB57K\*, ZS19K\* to ZS45K\*, ZF06K\* to ZF18K\* TF\* range of compressors the following circuit diagrams can be used:

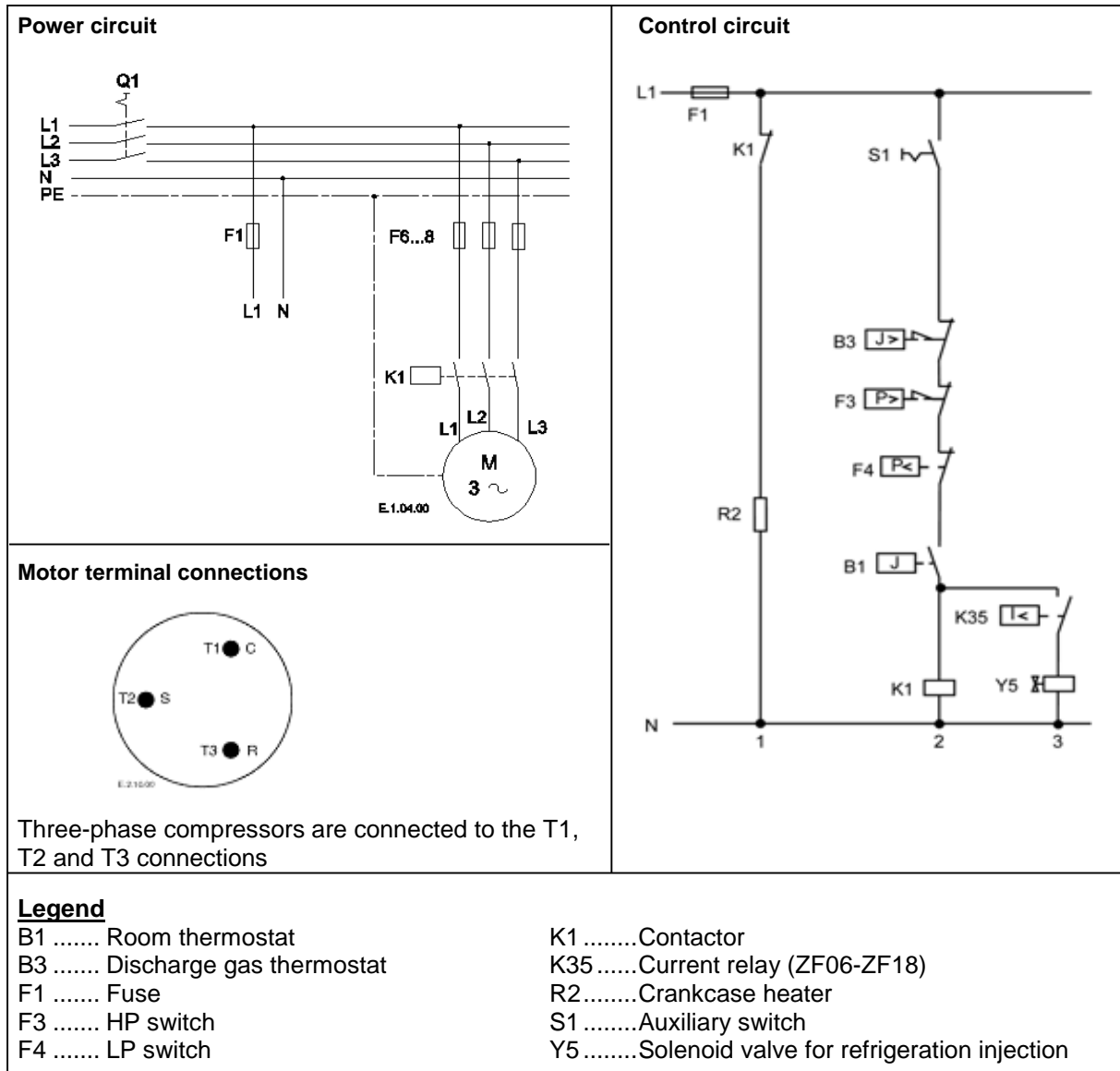

Figure 12

# Copeland Scroll™

## Three-phase compressors (TW\*) with external motor protection INT69SCY2:

For the ZB56K\* to ZB220K\*, ZS56K\* to ZS11M\*, ZF24K\* to ZF48K\* TW\* range of compressors the following circuit diagrams can be used:

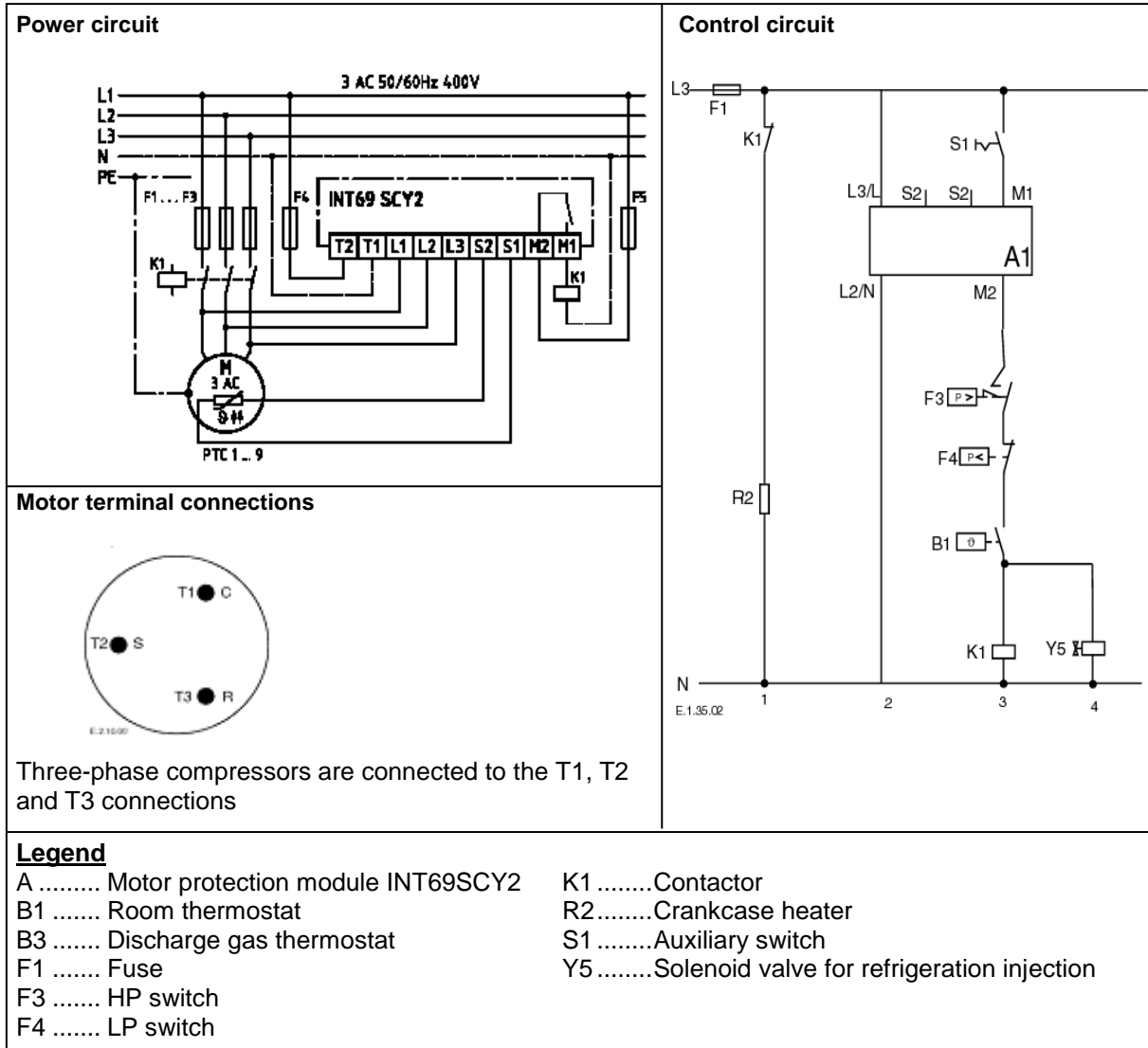

Figure 13

## 4.2.1 Terminal box

The standard terminal box is IP21 for all models with internal motor protection (TF\*/PF\*) and IP54 for all models with external motor protection (TW\*), enclosure class according to IEC 60034-5.

Cable glands have an influence on the protection class of the terminal box. It is strongly recommended to use appropriate cable glands in order to reach the rated protection class. We advise installers/service providers to pay attention to this aspect every time they install or replace a Copeland Scroll compressor and to use cable glands according to EN 50262 or any other relevant standard of application in their country/region. Examples of correct electrical installations are shown in **Figures 14 & 15** below.



Figure 14: Correct electrical installation with cable glands for IP21 T-box (models ZB15K\* to ZB45K\*)



Figure 15: Correct electrical installation with cable glands for IP54 T-box (model ZF33KVE)

## 4.2.2 Motor windings

These Scroll compressors are offered with either a single-phase or a three-phase induction motor, depending on the size. All three-phase motors are connected in star; single-phase motors need a run capacitor.

The motor insulation material is class "B" (TF\*) or "H" (TW\*) for compressor models covered in these guidelines.

## 4.2.3 Protection devices

Independently from the internal motor protection, fuses must be installed before the compressor. The selection of fuses has to be carried out according to VDE 0635, DIN 57635, IEC 269-1 or EN 60-269-1.

## 4.2.4 Crankcase heaters



### IMPORTANT

**Oil dilution! Bearing malfunction!** Turn the crankcase heater on 12 hours before starting the compressor.

A crankcase heater is used to prevent refrigerant migrating into the shell during standstill periods. Due to the Copeland scroll's inherent ability to handle liquid refrigerant in flooded conditions a crankcase heater is not required when the system charge does not exceed the charge limits indicated in **Table 6**.

Model		Refrigerant charge limit
Medium temperature	Low temperature	
ZB15K* to ZB29K* / ZS21K* to ZS26K*	ZF06K* to ZF11K*	3.6 kg
ZB30K* to ZB48K* / ZB57K* / ZS30K* to ZS45K*	ZF13K* & ZF18K*	4.5 kg
ZB56K* to ZB11M* / ZS56K* to ZS11M*	ZF24K* to ZF48K*	7.5 kg
ZB220K*		11.3 kg

Table 6

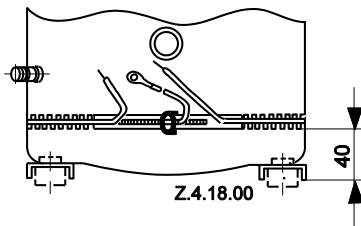

Figure 16: Crankcase heater location

If a crankcase heater is fitted it is recommended that the heater be turned on for a **minimum of 12 hours** prior to starting the compressor. This will prevent oil dilution and bearing stress on initial start up. The crankcase heater must remain energised during compressor off cycles.

The crankcase heater must be mounted below the oil schraeder valve located on the bottom shell (see **Figure 16**).

## 4.3 Pressure safety controls

### 4.3.1 High-pressure control

The cut-out setting for the high-pressure control shall be determined according to regional standards, usually EN 378, part 2 in Europe.

The maximum pressure value for the individual compressor type, PS high side, is printed on the nameplate of the compressor.

The high-pressure cut-out should have a manual reset feature for the highest level of system protection.

### 4.3.2 Low-pressure control

The minimum cut-out setting shall be determined according to the refrigerant and to the allowed operation envelope (see technical data in Select software). For example, a minimum cut-out setting of 0.3 bar(g) is required for ZF compressors using R404A.

The low-pressure cut-out should have a manual reset feature for the highest level of system protection.

### 4.3.3 Internal pressure relief valve

There is an internal pressure relief valve on all ZB15K\* to ZB48K\*, ZB57K\*, ZF06K\* to ZF18K\* and ZS21K\* to ZS45K\* refrigeration scroll compressors, which opens at a differential pressure of 28 bar  $\pm$  3 bar between high- and low-pressure sides. A high-pressure cut-out may be required according to national regulations and is strongly recommended due to the capabilities of pumping to high pressures once the discharge is obstructed. The IPR valve is a safety device, not an HP switch. It is not designed for repeated operation and there is no guarantee that it will reset correctly if it does have repeated operation.

## 4.4 Discharge temperature protection

The use of an external discharge thermostat is required for compressor models ZF06K\* to ZF18K\*, ZF13KVE to ZF18KVE and ZS21K\* to ZS45K\*.

A discharge thermostat can be used but is not mandatory for compressor models ZB15K\* to ZB45K\* because these models have an internal thermodisc which is positioned next to the discharge port of the scroll set. When the thermodisc opens, a small gas by-pass occurs which trips the Klixon motor protector.

The internal thermodisc opens at  $146^{\circ}\text{C} \pm 4\text{K}$  and closes at  $91^{\circ}\text{C} \pm 7\text{K}$ .

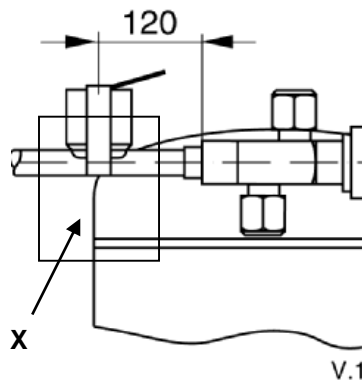

Figure 17: Discharge temperature protection recommended position

Internal discharge temperatures can reach unacceptable values under some extreme operating conditions (such as loss of refrigerant injection charge or extremely high compression ratio). This could cause compressor damage.

The R404A, R407A and R407F dedicated discharge thermostat has a cut-out setting of  $130^{\circ}\text{C} \pm 4\text{K}$  with closing at  $101^{\circ}\text{C} \pm 8\text{K}$  and should be installed approximately 120 mm from the discharge valve outlet (see Figure 17). It must be insulated in order to avoid improper functioning due to false readings (see "X" in Figure 17).

For compressors ZB56K\* to ZB11M\*; ZS56K\* to ZS11M\*; ZF24K\* to ZF48K\* and ZB220K\*, a thermistor is located in the discharge port of the fixed scroll. Excessive discharge temperature will cause the electronic protector module to trip. The discharge gas thermistor is wired in series with the motor thermistor chain.

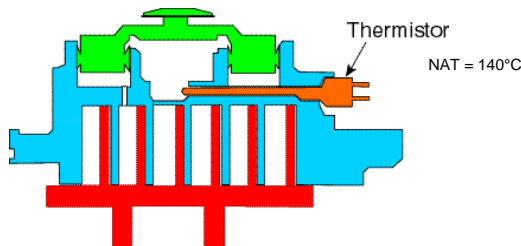

Figure 18: Internal discharge temperature sensor position

## 4.5 Motor protection

For the ZB15K\* to ZB48K\*, ZS21K\* to ZS45K\*, ZB57K\*, ZF06K\* to ZF18K\* range of compressors, conventional inherent internal line break motor protection is provided.

The electronic motor protection system used in all ZB56K\* to ZB220K\*, ZS56K\* to ZS11M\*, ZF24K\* to ZF48K\* models is identified by a "W" as the centre letter in the motor code. This system utilizes the temperature-dependent resistance of the thermistors (also called PTC-resistance) to read the winding temperature. A chain of four thermistors connected in series is embedded in the motor windings so that the temperature of the thermistors can follow the winding temperature with little inertia. An electronic module INT69SCY2 is required to process the resistance values and trip a control depending on the thermistor resistance.

### Protection module specifications

Type:.....Kriwan INT69SCY2  
 Dual voltage:..... 115 – 230V/120 – 240V AC 50/60 Hz , -15%...+10%, 3VA  
 Normal PTC resistance: ..... <1.8 kΩ  
 Trip resistance: ..... 4.50 kΩ ± 20%  
 Reset resistance:..... 2.75 kΩ ± 20%  
 Reset time delay:..... 30 minutes ± 5 minutes  
 Reset of running time..... Power interruption / mains failure approx. 5s  
 Phase monitor: ..... Yes  
 Ambient temperature range..... -30°C...+70°C

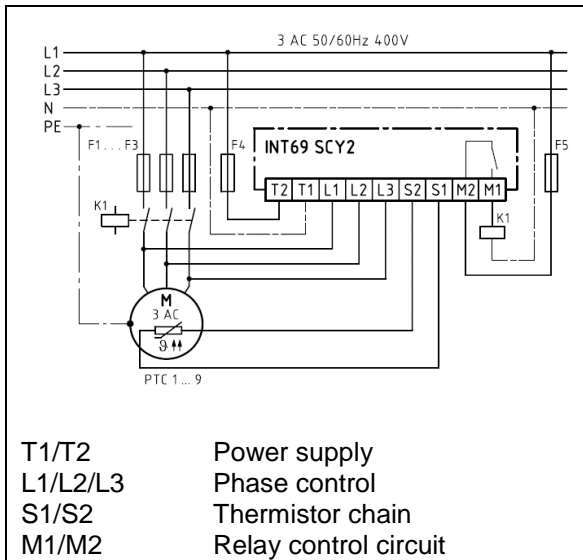

Figure 19: Wiring of the motor protection module

## Module

The INT69SCY2 hermetic motor protection module complies with IEC/EN 60335.

The module features mean that the refrigeration system would still be in a safe condition even if two faults were to occur. Backup is provided if the first fault protection should fail. An additional control contactor should be fitted to the system.

For protection in case of blocked rotor one thermistor for each phase is embedded in the winding heads on the upper (suction gas) side of the compressor motor. A fourth thermistor is located in a winding head at the lower end of the motor. A fifth sensor is located in the discharge port of the fixed scroll to control discharge-gas superheat. The entire chain is internally led to the fusite from where it is connected to the module connections S1 and S2. When any

resistance of the thermistor chain reaches the tripping value, the module interrupts the control line and causes the compressor to switch off. After the thermistor has cooled sufficiently, its resistance drops to the reset value but the module itself resets after a time delay of 30 minutes and restarts the compressor.

## 4.6 Phase protection

The phase protection capabilities of the INT69SCY2 module will sense the correct phase sequence of L1, L2, and L3 incoming power. Three-phase power must be wired in the correct phase sequence that will ensure the compressor will start and operate in the correct rotation. When the INT69SCY2 trips on phase loss a delay of 5 minutes is activated. If all three phases are present then the compressor will continue to run, if not the module will lock out.

After 10 attempts to restart the compressor, the module will lock out, which could be reset by re-establishing incoming power to the module.

## 4.7 Protector functional check and failure detection



### WARNING

**Conductor cables! Electrical shock!** Shut off power supply before and between each test.

Prior to start-up of the fully connected compressor a functional check shall be carried out:

- Disconnect one terminal either S1 or S2 of the protection module. If the compressor is now switched on, the motor should not start (simulation of an open thermistor chain).
- Reconnect the disconnected thermistor line. If the compressor is now switched on, the motor must start.

If the motor does not start up during the functional check, this indicates a disturbance in operation. The following steps should be followed:

### 4.7.1 Checking the connection

- Check the connection of the thermistor leads in the terminal box and at the protection module for possible loose connections or cable breakage.

If there is neither loose connection nor cable breakage the resistance of the thermistor chain must be checked.

### 4.7.2 Checking the compressor thermistor chain

**Caution:** Use maximum measuring voltage of 3V!

The thermistor leads at terminals S1 and S2 of the module shall be disconnected and the resistance measured between the leads. The resistance must be between 150 Ω and 1250 Ω.

- If the thermistor chain has a higher resistance (2750 Ω or higher), the motor temperature is still too high and it must be allowed to cool. Then measure again.
- If the resistance is below 30 Ω, the compressor has to be exchanged due to shorted sensor circuit.
- An infinite value indicates an open sensor circuit and the compressor has to be replaced.

If no defect is detected in the thermistor chain the module must be checked.

#### 4.7.3 Checking the protection module

The control connections at M1 and M2 have to be removed and the switching conditions must be checked by an ohmmeter or signal buzzer:

- Simulation of a short circuit in the thermistor chain (0 Ω): Bridge the already disconnected thermistor terminals S1 and S2 and switch on the voltage supply; the relay must switch on then off again after a short period; connection established then interrupted between terminals M1 and M2.
- Simulation of an open thermistor chain ( $\infty$  Ω): Remove the jumper used for the short-circuit simulation and switch on the voltage supply; the relay remains switched off; no connection between terminals M1 and M2.

If one of the above conditions is not met, the module is defective and has to be exchanged.

**NOTE: The function of the module should be tested each time the fuse in the control circuit breaks the power supply. This ensures the contacts did not stick.**

#### 4.8 High-potential testing



##### WARNING

**Conductor cables! Electrical shock!** Shut off power supply before high-potential testing.



##### CAUTION

**Internal arcing! Motor destruction!** Do not carry out high-voltage or insulation tests if the compressor housing is under vacuum.

Emerson Climate Technologies subjects all Scroll compressors to a high-voltage test after final assembly. Each motor phase winding is tested, according to EN 0530 or VDE 0530 part 1, at a differential voltage of 1000V plus twice the nominal voltage. Since high-voltage tests lead to premature ageing of the winding insulation further additional tests of that nature are not recommended.

If it has to be done for any reason, a lower voltage must be used. Disconnect all electronic devices, eg, motor protection module, fan speed control, etc prior to testing.

## 5 Starting up & operation

---



### WARNING

**Diesel effect! Compressor destruction!** The mixture of air and oil at high temperature can lead to an explosion. Avoid operating with air.



### IMPORTANT

**Oil dilution! Bearing malfunction!** Turn the crankcase heater on 12 hours before starting the compressor.

### 5.1 Strength pressure test

The compressor has been strength-tested in the factory. It is not necessary for the customer to strength- or leak-test the compressor again although the compressor will normally be exposed to the testing made as part of system testing.

### 5.2 Tightness/pressure test



### WARNING

**High pressure! Personal injuries!** Consider personal safety requirements and refer to test pressures prior to test.



### WARNING

**System explosion! Personal injuries! DO NOT USE** other industrial gases.



### CAUTION

**System contamination! Bearing malfunction!** Use only dry nitrogen or dried air for pressure testing.

If using dry air do not include the compressor in the pressure test – isolate it first. Never add refrigerant to the test gas (as leak indicator).

### 5.3 System evacuation

Before the installation is put into commission, it has to be evacuated with a vacuum pump. Proper evacuation reduces residual moisture to 50 ppm. During the initial procedure, suction and discharge shutoff valves on the compressor remain closed. The installation of adequately sized access valves at the furthest point from the compressor in the suction and liquid lines is advisable. Pressure must be measured using a vacuum pressure (Torr) gauge on the access valves and not on the vacuum pump; this serves to avoid incorrect measurements resulting from the pressure gradient along the connecting lines to the pump.

Evacuating the system only on the suction side of a Scroll compressor can occasionally result in a temporary no start condition for the compressor. The reason for this is that the floating seal could axially seal with the scroll set, with the higher pressure on the floating seal. Consequently, until the pressures equalise, the floating seal and scroll set can be held tightly together. The installation should be evacuated down to 0.3 mbar / 0.22 Torr.

Subsequently, the factory holding charge of dry air in the compressor is released to the ambient. The shut-off valves are opened and the installation, including the compressor, are once more evacuated as described after the system has been recharged with dry nitrogen. Highest demands are placed on the leak proof design of the installation and on leak testing methods (please refer to EN 378).

## 5.4 Preliminary checks – Pre-starting

Discuss details of the installation with the installer. If possible, obtain drawings, wiring diagrams, etc.

It is ideal to use a check-list but always check the following:

- Visual check of the electrics, wiring, fuses etc
- Visual check of the plant for leaks, loose fittings such as TXV bulbs etc
- Compressor oil level
- Calibration of HP & LP switches and any pressure actuated valves
- Check setting and operation of all safety features and protection devices
- All valves in the correct running position
- Pressure and compound gauges fitted
- Correctly charged with refrigerant
- Compressor electrical isolator location & position

## 5.5 Charging procedure



### CAUTION

**Low suction pressure operation! Compressor Damage!** Do not operate with a restricted suction. Do not operate with the low-pressure cut-out bridged. Do not operate compressor without enough system charge to maintain at least 0.3 bar suction pressure. Allowing pressure to drop below 0.3 bar for more than a few seconds may overheat scrolls and cause early drive bearing damage.

The system should be liquid-charged through the liquid-receiver shut-off valve or through a valve in the liquid line. The use of a filter drier in the charging line is highly recommended. Because scrolls have discharge check valves, systems should be liquid-charged on both the high and low sides simultaneously to ensure a positive refrigerant pressure is present in the compressor before it runs. The majority of the charge should be placed in the high side of the system to prevent bearing washout during first-time start on the assembly line.

## 5.6 Initial start-up



### CAUTION

**Oil dilution! Bearing malfunction!** It is important to ensure that new compressors are not subjected to liquid abuse. Turn the crankcase heater on 12 hours before starting the compressor.



### CAUTION

**High discharge pressure operation! Compressor damage!** Do not use compressor to test opening set point of high-pressure cut-out. Bearings are susceptible to damage before they have had several hours of normal running in.

Liquid and high pressure loads could be detrimental to new bearings. It is therefore important to ensure that new compressors are not subjected to liquid abuse and high-pressure run tests. It is not good practice to use the compressor to test the high-pressure switch function on the production line. Switch function can be tested with nitrogen prior to installation and wiring can be checked by disconnecting the high-pressure switch during the run test.

## 5.7 Rotation direction

Scroll compressors, like several other types of compressors, will only compress in one rotational direction. Direction of rotation is not an issue with single-phase compressors since they will always start and run in the proper direction. Three-phase compressors will rotate in either direction depending upon phasing of the power to L1, L2 and L3. Since there is a 50/50 chance of connecting power in such a way as to cause rotation in the reverse direction, **it is important to include notices and instructions in appropriate locations on the equipment to ensure proper rotation direction is achieved when the system is installed and operated.**

Observing that suction pressure drops and discharge pressure rises when the compressor is energized allows verification of proper rotation direction. There is no negative impact on

# Copeland Scroll™

durability caused by operating three-phase Copeland Scroll™ compressors in the reversed direction for a short period of time (under one hour) but oil may be lost. Oil loss can be prevented during reverse rotation if the tubing is routed at least 15 cm above the compressor. After several minutes of operation in reverse, the compressor protection system will trip due to high motor temperature. The operator will notice a lack of cooling. However, if allowed to repeatedly restart and run in reverse without correcting the situation, the compressor will be permanently damaged.

All three-phase Scroll compressors are identically wired internally. Therefore, once the correct phasing is determined for a specific system or installation, connecting properly phased power leads to the identified compressor terminals will ensure proper rotation direction.

Compressors ZB56K\* to ZB220K\*, ZS56K\* to ZS11M\* and ZF24K\* to ZF48K\* have an electronic protection unit (INT69SCY2) that will not let the compressor operate if the phasing of the wires is incorrect.

## 5.8 Starting sound

During the very brief start-up, a clicking sound is audible, resulting from initial contacting of the spirals and is normal. No start assist devices are required for single-phase compressors, even if a system uses non-bleed expansion valves. Due to the design of the Copeland Scroll, the internal compression components always start unloaded even if system pressures are not balanced. In addition, since internal compressor pressures are always balanced at start-up, low-voltage starting characteristics are excellent for Copeland Scroll™ compressors. Moreover, if low voltage conditions exist at start up, protector trips could result.

## 5.9 Deep vacuum operation



### CAUTION

**Vacuum operation! Compressor damage!** Scroll compressors should never be used to evacuate a refrigeration or air-conditioning system.

The Scroll compressor can be used to pump down refrigerant in a unit as long as the pressures remain within the operating envelope. Low suction pressures will result in overheating of the scrolls and permanent damage to the compressor drive bearing. Scroll compressors incorporate internal low vacuum protection; the floating seal unloads when the pressure ratio exceeds approximately 20:1 for ZS and ZF and 10:1 for ZB.

## 5.10 Shell temperature

The top shell and discharge line can briefly but repeatedly reach temperatures above 177°C if the compressor cycles on its internal protection devices. This only happens under rare circumstances and can be caused by the failure of system components such as the condenser or evaporator fan or loss of charge and depends upon the type of expansion control. Care must be taken to ensure that wiring or other materials that could be damaged by these temperatures do not come in contact with the shell.

## 5.11 Pump-down cycle

To control refrigerant migration a pump-down system should be used. The discharge check valve with a refrigeration scroll compressor is designed for low leak back and will allow the use of a pump-down without the addition of an external check valve.

If the compressor is stationary for prolonged periods, refrigerant could migrate into the compressor and therefore a crankcase heater must be installed.

If cold air is constantly drawn over the compressor this could make the crankcase heater ineffective and therefore a pump-down system is recommended.

For ZB models care should be taken because the scroll sets will unload at a pressure ratio of approximately 10:1. If the unit fails to pump down the pump-down pressure should be reset to a higher value. The low-pressure control differential for all models needs to be reviewed since a relatively lower volume of gas will reexpand from the discharge plenum of the compressor into the low side on shutdown.

## 5.12 Minimum run time

Emerson Climate Technologies recommends a maximum of 10 starts per hour. There is no minimum off time because Scroll compressors start unloaded even if the system has unbalanced pressures. The most critical consideration is the minimum run time required to return oil to the compressor after start-up. To establish the minimum run time obtain a sample compressor equipped with a sight tube (available from Emerson Climate Technologies) and install it in a system with the longest connecting lines that are approved for the system. The minimum on time becomes the time required for oil lost during compressor start-up to return to the compressor sump and restore a minimal oil level that will ensure oil pick-up through the crankshaft. Cycling the compressor for a shorter period than this, for instance to maintain very tight temperature control, will result in progressive loss of oil and damage to the compressor.

## 5.13 Shut-off sound

Scroll compressors incorporate a device that minimizes reverse rotation. The residual momentary reversal of the scrolls at shut off will cause a clicking sound, but it is entirely normal and has no effect on compressor durability.

## 5.14 Frequency

There is no general release of standard Copeland Scroll compressors for use with variable speed AC drives. There are numerous issues that must be considered when applying Scroll compressors with variable speed, including system design, inverter selection, and operating envelopes at various conditions. Only frequencies from 50 Hz to 60 Hz are acceptable. Operation outside this frequency range is possible but should not be done without specific Application Engineering review. The voltage must vary proportionally to the frequency.

If the inverter can only deliver a maximum voltage of 400V, the amps will increase when the speed is above 50 Hz, and this may give rise to nuisance tripping if operation is near the maximum power limit and/or compressor discharge temperature limit.

## 5.15 Oil level

The oil level should be maintained at mid-point of the sight glass. If an oil regulator is being used the level should be set within the top half of the sight glass.

## 6 Maintenance & repair

---

### 6.1 Exchanging the refrigerant

Qualified refrigerants and oils are given in section 2.3.1.

It is not necessary to replace the refrigerant with new unless contamination due to an error such as topping up the system with an incorrect refrigerant is suspected. To verify correct refrigerant composition, a sample can be taken for chemical analysis. A check can be made during shut down by comparing the refrigerant temperature and pressure using precision measurements at a location in the system where liquid and vapour phases are present and when the temperatures have stabilised.

In the event that the refrigerant needs replacing, the charge should be recovered using a suitable recovery unit.

### 6.2 Rotalock valves

Rotalock valves should be periodically re-torqued to ensure that leak tightness is maintained.

### 6.3 Replacing a compressor



#### CAUTION

**Inadequate lubrication! Bearing destruction!** Exchange the accumulator after replacing a compressor with a burned out motor. The accumulator oil return orifice or screen may be plugged with debris or may become plugged. This will result in starvation of oil to the new compressor and a second failure.

#### 6.3.1 Compressor replacement

In the case of a motor burnout, the majority of contaminated oil will be removed with the compressor. The rest of the oil is cleaned through the use of suction and liquid line filter driers. A 100% activated alumina suction line filter drier is recommended but must be removed after 72 hours. **It is highly recommended that the suction accumulator be replaced if the system contains one.** This is because the accumulator oil return orifice or screen may be plugged with debris or may become plugged shortly after a compressor failure. This will result in starvation of oil to the replacement compressor and a second failure. When a single compressor or tandem is exchanged in the field, it is possible that a major portion of the oil may still be in the system. While this may not affect the reliability of the replacement compressor, the extra oil will add to rotor drag and increase power usage.

#### 6.3.2 Start-up of a new or replacement compressor

Rapid charging only on the suction side of a scroll-equipped system or condensing unit can occasionally result in a temporary no start condition for the compressor. The reason for this is that, if the flanks of the compressor happen to be in a sealed position, rapid pressurisation of the low side without opposing high-side pressure can cause the scrolls to seal axially. As a result, until the pressures eventually equalise, the scrolls can be held tightly together preventing rotation. The best way to avoid this situation is to charge on both the high and low sides simultaneously at a rate which does not result in axial loading of the scrolls.

A minimum suction pressure of 1.75 bar must be maintained during charging. Allowing pressure to drop below 0.3 bar for more than a few seconds may overheat scrolls and cause early drive bearing damage. Never install a system in the field and leave it unattended when it has no charge, a holding charge, or with the service valves closed without securely electrically locking out the system. This will prevent unauthorised personnel from accidentally operating the system and potentially ruining the compressor by operating with no refrigerant flow. **Do not start the compressor while the system is in a deep vacuum.** Internal arcing may occur when a Scroll compressor is started in a vacuum causing burnout of the internal lead connections.

## 6.4 Lubrication and oil removal



### CAUTION

**Chemical reaction! Compressor destruction!** Do not mix up ester oils with mineral oil and/or alkyl benzene when used with chlorine-free (HFC) refrigerants.

The compressor is supplied with an initial oil charge. The standard oil charge for use with refrigerants R404A / R407A / R407F / R407C / R134a / R22 is a polyolester (POE) lubricant Emkarate RL 32 3MAF. In the field the oil level could be topped up with Mobil EAL Arctic 22 CC if 3MAF is not available. See nameplate for original oil charge shown in litres. A field recharge is from 0.05 to 0.1 litre less.

One disadvantage of POE is that it is far more hygroscopic than mineral oil (see **Figure 20**). Only brief exposure to ambient air is needed for POE to absorb sufficient moisture to make it unacceptable for use in a refrigeration system. Since POE holds moisture more readily than mineral oil it is more difficult to remove it through the use of vacuum. Compressors supplied by Emerson Climate Technologies contain oil with low moisture content, and it may rise during the system assembling process. Therefore it is recommended that a properly sized filter-drier is installed in all POE systems. This will maintain the moisture level in the oil to less than 50 ppm. If oil is charged into a system, it is recommended to use POE with a moisture content no higher than 50 ppm.

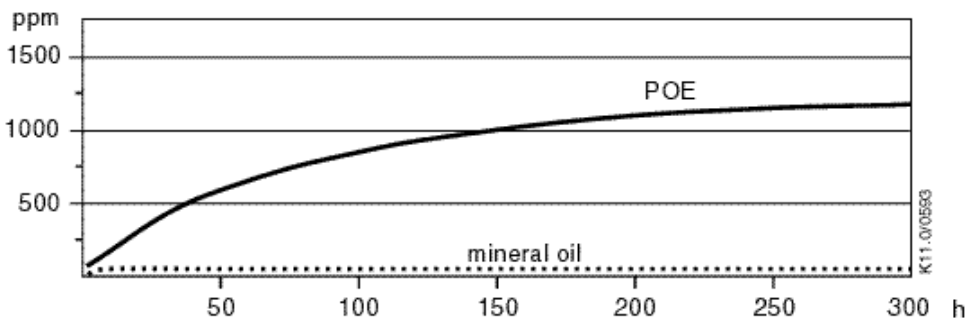

**Figure 20: Absorption of moisture in ester oil in comparison to mineral oil in ppm by weight at 25°C and 50% relative humidity (h=hours)**

If the moisture content of the oil in a refrigeration system reaches unacceptably high levels, corrosion and copper plating may occur. The system should be evacuated down to 0.3 mbar or lower. If there is uncertainty as to the moisture content in the system, an oil sample should be taken and tested for moisture. Sight glass/moisture indicators currently available can be used with the HFC refrigerants and lubricants; however, the moisture indicator will just show the moisture content of the refrigerant. The actual moisture level of POE would be higher than the sight glass indicates. This is due to the high hygroscopicity of the POE oil. To determine the actual moisture content of the lubricant, samples have to be taken from the system and analysed.

## 6.5 Oil additives

Although Emerson Climate Technologies cannot comment on any specific product, from our own testing and past experience, we do not recommend the use of any additives to reduce compressor bearing losses or for any other purpose. Furthermore, the long term chemical stability of any additive in the presence of refrigerant, low and high temperatures, and materials commonly found in refrigeration systems is complex and difficult to evaluate without rigorously controlled chemical laboratory testing. The use of additives without adequate testing may result in malfunction or premature failure of components in the system and, in specific cases, in voiding the warranty on the component.

## 6.6 Unbrazing system components



### WARNING

**Explosive flame! Burning!** Oil-refrigerant mixtures are highly flammable. Remove all refrigerant before opening the system. Avoid working with an unshielded flame in a refrigerant charged system.

# Copeland Scroll™

Before opening up a system it is important to remove all refrigerant from both the high and low sides of the system. If the refrigerant charge is removed from a scroll equipped unit from the high side only, it is possible for the scrolls to seal, preventing pressure equalization through the compressor. This may leave the low side shell and suction line tubing pressurized. If a brazing torch is then applied to the low side while the low side shell and suction line contain pressure, the pressurized refrigerant and oil mixture could ignite when it escapes and contacts the brazing flame. To prevent this occurrence, it is important to check both the high and low sides with manifold gauges before unbrazing. Instructions should be provided in appropriate product literature and assembly (line repair) areas. If compressor removal is required, the compressor should be cut out of system rather than unbrazed.

## 7 Dismantling & disposal

---



**Removing oil and refrigerant:**  
**Do not disperse in the environment.**  
**Use the correct equipment and method of removal.**  
**Dispose of oil and refrigerant properly.**  
**Dispose of compressor properly.**

## DISCLAIMER

---

1. The contents of this publication are presented for informational purposes only and are not to be construed as warranties or guarantees, express or implied, regarding the products or services described herein or their use or applicability.
2. Emerson Climate Technologies GmbH and/or its affiliates (collectively "Emerson"), as applicable, reserve the right to modify the design or specifications of such products at any time without notice.
3. Emerson does not assume responsibility for the selection, use or maintenance of any product. Responsibility for proper selection, use and maintenance of any Emerson product remains solely with the purchaser or end user.
4. Emerson does not assume responsibility for possible typographic errors contained in this publication.



#### BENELUX

Josephinastraat 19  
NL-6462 EL Kerkrade  
Tel. +31 77 324 02 34  
Fax +31 77 324 02 35  
benelux.sales@emerson.com

#### GERMANY, AUSTRIA & SWITZERLAND

Senefeldler Str. 3  
DE-63477 Maintal  
Tel. +49 6109 605 90  
Fax +49 6109 60 59 40  
ECTGermany.sales@emerson.com

#### FRANCE, GREECE & MAGHREB

8, Allée du Moulin Berger  
FR-69134 Ecully Cédex  
Tel. +33 4 78 66 85 70  
Fax +33 4 78 66 85 71  
mediterranean.sales@emerson.com

#### ITALY

Via Ramazzotti, 26  
IT-21047 Saronno (VA)  
Tel. +39 02 96 17 81  
Fax +39 02 96 17 88 88  
italy.sales@emerson.com

#### SPAIN & PORTUGAL

C/ Pujades, 51-55 Box 53  
ES-08005 Barcelona  
Tel. +34 93 412 37 52  
Fax +34 93 412 42 15  
iberica.sales@emerson.com

#### UK & IRELAND

Unit 17, Theale Lakes Business Park  
Reading, Berkshire RG7 4GB  
Tel: +44 1189 83 80 00  
Fax: +44 1189 83 80 01  
uk.sales@emerson.com

#### SWEDEN, DENMARK, NORWAY & FINLAND

Norra Koxåsvägen 7  
SW-443 38 Lerum  
Tel. +46 725 386486  
nordic.sales@emerson.com

#### EASTERN EUROPE & TURKEY

Pascalstr. 65  
DE-52076 Aachen  
Tel. +49 2408 929 0  
Fax +49 2408 929 525  
easterneurope.sales@emerson.com

#### POLAND

Szturmowa 2  
PL-02678 Warsaw  
Tel. +48 22 458 92 05  
Fax +48 22 458 92 55  
poland.sales@emerson.com

#### RUSSIA & CIS

Emerson LLC  
Dubininskaya str. 53, build. 5, 4th floor  
115054 Moscow, Russia  
Phone: +7 (495) 995 95 59  
Fax: +7 (495) 424 88 50

#### BALKAN

Selska cesta 93  
HR-10 000 Zagreb  
Tel. +385 1 560 38 75  
Fax +385 1 560 38 79  
balkan.sales@emerson.com

#### ROMANIA

Tel. +40 374 13 23 50  
Fax +40 374 13 28 11  
Ancuta.Ionescu@Emerson.com

#### ASIA PACIFIC

Suite 2503-8, 25/F, Exchange Tower  
33 Wang Chiu Road, Kowloon Bay  
Kowloon, Hong Kong  
Tel. +852 2866 3108  
Fax +852 2520 6227

#### MIDDLE EAST & AFRICA

PO Box 26382  
Jebel Ali Free Zone - South, Dubai - UAE  
Tel. +971 4 811 81 00  
Fax +971 4 886 54 65  
mea.sales@emerson.com

For more details, see [www.emersonclimate.eu](http://www.emersonclimate.eu)

Connect with us: [facebook.com/EmersonClimateEurope](https://facebook.com/EmersonClimateEurope)



Emerson Climate Technologies - European Headquarters - Pascalstrasse 65 - 52076 Aachen, Germany  
Tel. +49 (0) 2408 929 0 - Fax: +49 (0) 2408 929 570 - Internet: [www.emersonclimate.eu](http://www.emersonclimate.eu)

The Emerson Climate Technologies logo is a trademark and service mark of Emerson Electric Co. Emerson Climate Technologies Inc. is a subsidiary of Emerson Electric Co. Copeland is a registered trademark and Copeland Scroll is a trademark of Emerson Climate Technologies Inc. All other trademarks are property of their respective owners. Emerson Climate Technologies GmbH shall not be liable for errors in the stated capacities, dimensions, etc., as well as typographic errors. Products, specifications, designs and technical data contained in this document are subject to modification by us without prior notice. Illustrations are not binding.  
© 2015 Emerson Climate Technologies, Inc.



**EMERSON. CONSIDER IT SOLVED.™**