



TCS4

DEFROST TIMER



OPERATING INSTRUCTIONS

Vr. 03 (ENG) - 17/07 - cod.: ISTR-MTCS4-ENG03

ASCON TECNOLOGIC S.r.l.

Viale Indipendenza 56, 27029 - VIGEVANO (PV) ITALY
Tel.: +39 0381 69871 - Fax: +39 0381 698730
<http://www.ascontecnologic.com>
info@ascontecnologic.com

PREFACE

 This manual contains the information necessary for the product to be installed correctly and also instructions for its maintenance and use; we therefore recommend that the utmost attention is paid to the following instructions and to save it.

This document is the exclusive property of Ascon Tecnologic S.r.l. which forbids any reproduction and divulgation, even partially, of the document, unless expressly authorized.

Ascon Tecnologic S.r.l. reserves the right to make any formal or functional changes at any moment and without any notice.

 Ascon Tecnologic S.r.l. and its legal representatives do not assume any responsibility for any damage to people, things or animals deriving from violation, wrong or improper use or in any case not in compliance with the instrument features.

 Whenever a failure or a malfunction of the device may cause dangerous situations for persons, thing or animals, please remember that the plant has to be equipped with additional electromechanical devices which will guarantee safety.

1. INSTRUMENT DESCRIPTION

TCS4 is a timer intended for specific use in refrigeration systems to determine defrosting cycle; it can control the defrosting cycle programming intervals and duration. End defrosting temperature can be determined using an external NC thermal-switch collocated on evaporator. It is also possible to carry out the fans stop, during defrost, and re-start after a defrost cycle. By means of a key it is possible to launch a manual defrost.

1.1 Front panel description

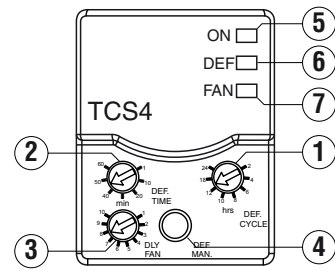

1. **DEF CYCLE:** Trimmer for setting the Defrost interval;
2. **DEF TIME:** Trimmer for setting the Defrost duration;
3. **DLY FAN:** Trimmer for setting the Fan delay after defrost;
4. **DEF MAN:** Manual Defrost key;
5. **Led ON:** Indicates the power-on of the instrument;
6. **Led DEF:** Indicates defrost cycle in progress,
7. **Led FAN:** Indicates FAN output on.

2. PROGRAMUSAGE WARNINGS

2.1 Admitted use

 The instrument has been projected and manufactured as a measuring and control device to be used according to EN60730-1 at altitudes operation below 2000 m.

Using the instrument for applications not expressly permitted by the above mentioned rule must adopt all the necessary protective measures. The instrument **MUST NOT BE USED** in dangerous environments (flammable or explosive) without adequate protections. The installer must ensure that the EMC rules are respected, also after the instrument installation, if necessary using proper filters.

3. INSTALLATION WARNINGS

3.1 Mechanical mounting

The instrument, in a 2 DIN modules case, is designed for inside enclosure mounting on DIN rail. Avoid placing the instrument in environments with very high humidity levels or dirt that may create condensation or introduction of conductive substances into the instrument. Ensure adequate ventilation to the instrument and avoid installation in containers that house devices which may overheat or which may cause the instrument to function at a higher temperature than the one permitted and declared. Connect the instrument as far away as possible from sources of electromagnetic disturbances such as motors, power relays, relays, solenoid valves, etc.

3.2 Electrical connections

 Carry out the electrical wiring by connecting only one wire to each terminal, according to the following diagram, checking that the power supply is the same as that indicated on the instrument and that the load current absorption is no higher than the maximum electricity current permitted. As the instrument is built-in equipment with permanent connection inside housing, it is not equipped with either switches or internal devices to protect against overload of current: the installation will include an overload protection and a two-phase circuit-breaker, placed as near as possible to the instrument, and located in a position that can easily be reached by the user and marked as instrument disconnecting device which interrupts the power supply to the equipment. It is also recommended that the supply of all the electrical

circuits connected to the instrument must be protected properly, using devices (ex. fuses) proportionate to the circulating currents. It is strongly recommended that cables with proper insulation, according to the working voltages and temperatures, be used. Furthermore, the input cable has to be kept separate from line voltage wiring. If the input cable is screened, it has to be connected to the ground with only one side.



We recommend that a check should be made that the parameters are those desired and that the application functions correctly before connecting the outputs to the actuators so as to avoid malfunctioning that may cause irregularities in the plant that could cause damage to people, things or animals.

3.2.1 Electrical wiring diagram

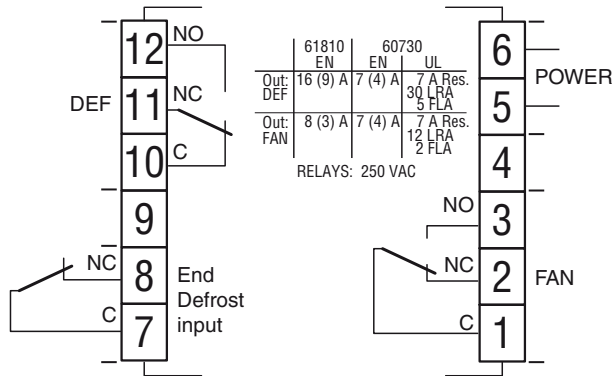

4. MAINTENANCE AND WARRANTY

4.1 Cleaning

We recommend cleaning of the instrument only with a slightly wet cloth using water and not abrasive cleaners or solvents.

4.2 Warranty and Repairs

The instrument is under warranty against manufacturing flaws or faulty material, that are found within 18 months from delivery date. The warranty is limited to repairs or to the replacement of the instrument. The eventual opening of the housing, the violation of the instrument or the improper use and installation of the product will bring about the immediate withdrawal of the warranty effects. In the event of a faulty instrument, either within the period of warranty, or further to its expiry, please contact our sales department to obtain authorisation for sending the instrument to our company. The faulty product must be shipped to Ascon Tecnologic with a detailed description of the faults found, without any fees or charge for Ascon Tecnologic, except in the event of alternative agreements.

4.3 Disposal



The appliance (or the product) must be disposed of separately in compliance with the local standards in force on waste disposal.

5. TECHNICAL DATA

5.1 Electrical characteristics

Power supply: 24 VAC/VDC, 100... 240 ±10%;

AC frequency: 50/60 Hz;

Power consumption: about 3 VA;

Inputs: 1 defrost-end input for NC thermostat;

Output: 2 relay outputs SPDT;

	EN 61810	EN 60730	UL 60730
DEF SPDT - 16A - 1HP 250V, 1/2HP 125 VA	16 (9) A	7 (4) A	7 A Res., 30 LRA, 5 FLA
FAN SPDT - 8A - 1/2 HP 250V, 1/3 HP 125 VA	8 (3) A		

Relay output Electrical life: 100000 operations;

Action type: Type 1.B (EN 60730-1);

Overvoltage category: II;

Protection class: Class II;

5.2 Mechanical characteristics

Housing: Self-extinguishing plastic, UL 94 V0;

Heat and fire resistance category: D;

Ball Pressure Test as described in EN60730: accessible parts 75°C; support live parts 125°C;

Dimensions: 35 x 90 mm, depth 73 mm;

Weight: About 120 g;

5.2.1 Mechanical dimensions [mm]

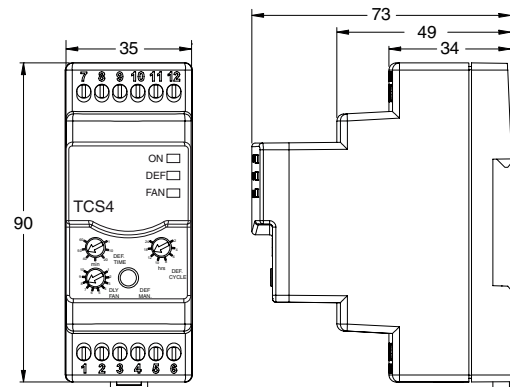

Mounting: Incorporated device, mounting on omega DIN rail;

Connections: Fixed screw terminals for 0.2... 2.5 mm²/ AWG 24... 14 cables;

Pollution degree: 2;

Operating temperature: 0... 50°C;

Operating humidity: < 95 RH% with no condensation;

Storage temperature: -25... +60°C.

6. INSTRUMENT ORDERING CODE

Model TCS4 - = Defrost timer
Power supply H = 100... 240 VAC L = 24 VAC/DC
End Defrost Temperature Input - = Klixon Contact/Thermostat 12 = NTC Input - End defrost temperature 12°C
Defrost Interval - = 2... 24 h B = 30 min/4 h
Defrost Duration - = 1... 60 min B = 1... 7 min
Fan activation delay - = 1... 10 min B = Fixed: 15 s