

# EWDR 72

rel. 9/96 ing  
defrost timer DIN rail

## WHAT IT IS

The EWDR 72 has been designed specifically to be used as defrost timer in refrigeration systems.

## HOW IT IS MADE

- **Housing material:** self-extinguish ABS plastic
- **Dimensions:** 4-module DIN, 70x85 mm front
- **Mounting:** on DIN-rail (omega 3) or wallmount
- **Connections:** terminal block for max 2.5 mm<sup>2</sup> wiring
- **Defrost frequency:** from 2 to 30 hours, in 2-hour increments
- **Length of defrost:** from 1 to 60 minutes
- **Klixon-type input:** terminals for remote klixon signal (for temperature termination)
- **Manual defrost:** push-button provided
- **Defrost output:** SPDT relay 8(3)A 250V AC
- **Fan delayed start:** adjustable between 1 and 10 minutes
- **Fan control output:** SPDT relay 8(3)A 250V AC
- **Power absorption:** 160 mA max
- **Power supply:** 220/110 Vac, 50/60 Hz or 12 Vac/dc. Others on request

## GENERAL DESCRIPTION

The EWDR 72 has been designed specifically to be used as defrost timer in refrigeration systems.

The EWDR 72 comes in a 4-module DIN housing suitable for DIN-rail mounting. As with the EWTS 70, it controls the intervals between defrost cycles (adjustable from 2 to 30 hours, in 2 hour increments) as well as the duration of the defrost (from 1 to 60 minutes).

Likewise, the defrost output can also be controlled by a klixon-type device (not supplied); in addition, a button is provided on the front panel to perform a manual defrost. The EWDR 72 also provides fan cut-out during the defrost as well as restart of the fan subject to a time delay (adjustable with a trimmer).

The adjustment of times and temperatures is extremely easy as it is obtained by means of mini trimmers indicating the setting and mini switches which are selectable according to a table printed on the instrument itself. On its front side a series of leds permits the read-out of the running cycle (normal defrost, fan delay).

This defrost timer provides an esthetical match with the corresponding ELIWELL temperature controllers, i.e. EWDR series (DIN-rail mount). The combination of an ELIWELL defrost timer and an ELIWELL temperature control provides a comprehensive and easy to operate modular control system which fits attractively in any modern refrigeration or freezer unit.

## PANEL LAY-OUT AND SYSTEM SET-UP

**"POWER" led:** green "power on" light.

**"DEFROST" led:** red "defrost in progress" light.

**"FANS" led:** green status light for the fan(s); it stays on to indicate that the fan is running; it flashes when the fan is in a delay-before-start mode (i.e. after a defrost).

**"DEFROST INTERVAL" dip-switches** (1, 2, 3 and 4); to select the time interval between the defrost cycles. The required setting is achieved by adding the values assigned to each of these 4 dip-switches. For instance, by setting only switch 1 (value = 2) at "ON", the defrost frequency is 2 hours; a 6-hour frequency is achieved by setting switches 1 and 2 in the "ON" position, with 3 and 4 in "OFF".

**"DEFROSTING TIME" trimmer:** screwdriver operated slotted trimmer for the setting, in minutes, of the desired length of a defrost cycle.

**"FAN DELAY TIME" trimmer:** screwdriver operated slotted trimmer to set the time delay (in minutes) for the fan, after a defrost cycle or after system start-up.

**"MANUAL" button:** pushbutton to start a defrost cycle manually.

## OPERATION

The green "POWER" status light will come on as soon as power is connected to the instrument. The fan remains off according to the selected fan time delay which is indicated by the flashing green "FANS" led. After this time delay the fan is started and the green "FANS" light stops flashing (stays on steady).

A timed defrost cycle is started automatically: the corresponding relay is energized, provided however that the klixon input is closed (install a jumper if this input is not



## CONNECTIONS

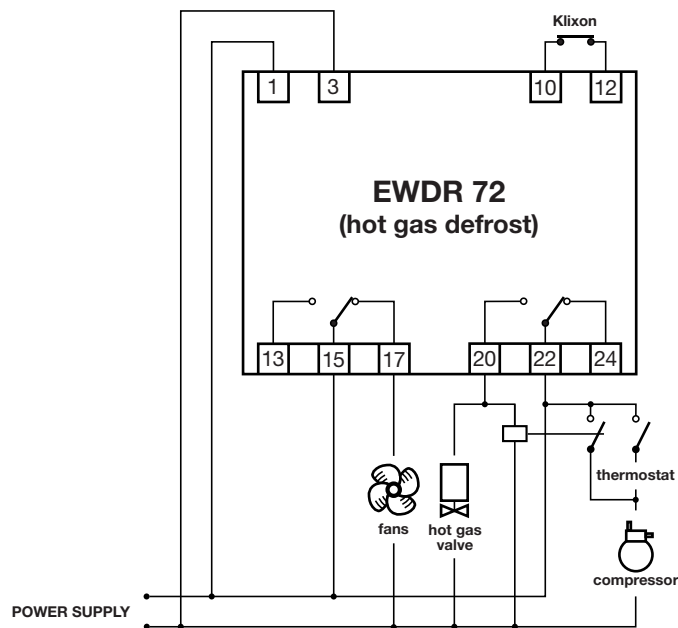
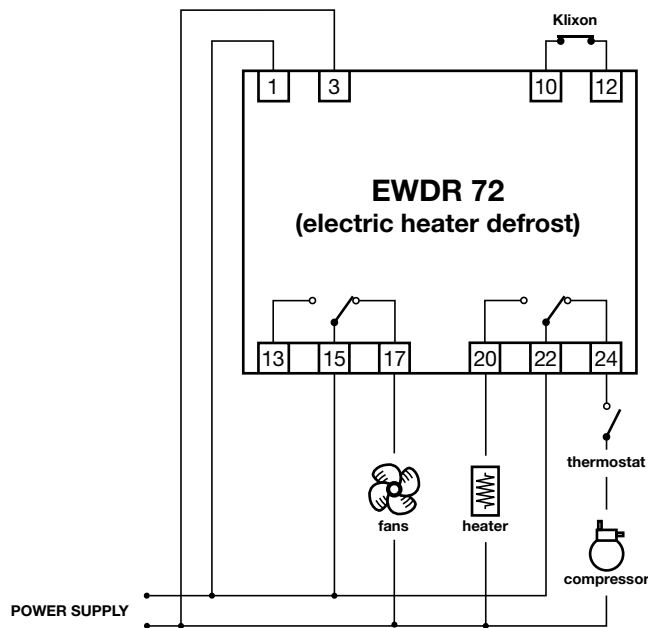

used). At this time, the red "DEFROST" led will come on to indicate that a defrost is in progress. The green "FANS" led will go out to indicate that the fan has been turned off during the defrost. The defrost cycle is terminated as soon as the programmed time period has lapsed (the "time-out"), or when the klixon reaches the termination temperature.

It is also possible to start a manual defrost cycle at any time simply by pressing the appropriate button.

After a power failure the timer resets itself to the start of a countdown.

After the defrost cycle, the re-starting of the fan is delayed; the green "FANS" led will flash. After this time delay the fan start

running while the green "FANS" led will change from flashing into steady.

### TECHNICAL DATA

**Housing material:** self-extinguish ABS plastic.

**Dimensions:** 4-module DIN, 70x85 mm front.

**Mounting:** on DIN-rail (omega 3) or wall-mount.

**Connections:** terminal block for max 2.5 mm<sup>2</sup> wiring.

**Operating temperature:** -5...65 °C; (23...149 °F).

**Storage temperature:** -30...75 °C; (-22...167 °F).

**Defrost frequency:** from 2 to 30 hours, in

2-hour increments.

**Length of defrost:** from 1 to 60 minutes.

**Klixon-type input:** terminals for remote klixon signal (for temperature termination).

**Manual defrost:** push-button provided.

**Defrost output:** SPDT relay 8(3)A 250V AC.

**Fan delayed start:** adjustable between 1 and 10 minutes.

**Fan control output:** SPDT relay 8(3)A 250V AC.

**Power absorption:** 160 mA max.

**Power supply:** 220/110 Vac, 50/60 Hz or 12 Vac/dc. Others on request.

### Eliwell S.p.A.

via dell'Artigianato, 65  
Zona Industriale  
32010 Pieve d'Alpago (BL)  
Italy

Telephone +39 (0)437 986111

Facsimile +39 (0)437 989066

### A Siebe Group Company