

MaEr Fan Motor

Professional · Honest · Human Oriented

EC SMART FAN EC智能风机系列

CATALOG III



浙江马尔风机有限公司
ZHEJIANG MAER FAN MOTOR CO.,LTD.



杭州马尔微电机有限公司
HANGZHOU MAER MICRO-MOTOR CO.,LTD.

地址 Add: 浙江省海宁市长安镇创业路333号
NO. 333 Chuangye Road, Chang'an Town, Haining City, Zhejiang, China
邮编 P.C.: 314408
电话 Tel: +86 573 87961785 87961786
传真 Fax: +86 573 87123938 87961787
网址 Website: www.zjmaerfj.com
邮箱 E-mail: sales@maerfj.com

浙江亿利达风机股份有限公司
ZHEJIANG YILIDA VENTILATOR CO., LTD.



地址 Add: 中国浙江台州市路桥区横街亿利达路
Yilida Road, Hengjie, Luqiao District, Taizhou City, Zhejiang, China
邮编 P.C.: 318056
电话 Tel: +86 576 82656000 +86 576 82658900
传真 Fax: +86 576 82655758
网址 Website: www.yilida.com
邮箱 E-mail: info@yilida.com
全球服务热线 Hot Line: 400 1135 666
国际贸易 Global Trade: +86 576 82622666

亿利达股份成员企业 MEMBER OF YILIDA GROUP

浙江马尔风机有限公司 杭州马尔微电机有限公司
ZHEJIANG MAER FAN MOTOR CO.,LTD. HANGZHOU MAER MICRO-MOTOR CO.,LTD.



MaEr Fan Motor

Professional · Honest · Human Oriented



MaEr Fan Motor

Professional · Honest · Human Oriented



Yilida
info@yilida.com



ECM 电机
ECM MOTOR

05



EC外转子轴流风机
EC AXIAL FAN

09



EC外转子离心风机
EC CENTRIFUGAL FAN

37

CATALOG / 目录

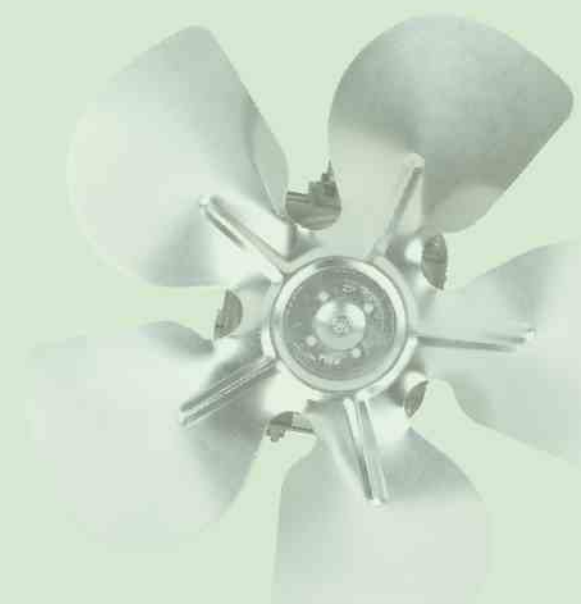

ECM 电机 ECM MOTOR EC外转子轴流风机 EC AXIAL FAN EC外转子离心风机EC CENTRIFUGAL FAN EC
MOTOR EC外转子轴流风机 EC AXIAL FAN EC外转子离心风机EC CENTRIFUGAL FAN ECM 电机 ECM MO
C外转子轴流风机 EC AXIAL FAN EC外转子离心风机EC CENTRIFUGAL FAN ECM 电机 ECM MOTOR EC外
机 EC AXIAL FAN EC外转子离心风机EC CENTRIFUGAL FAN ECM 电机 ECM MOTOR EC外转子轴流风机 E
EC外转子离心风机EC CENTRIFUGAL FAN ECM 电机 ECM MOTOR EC外转子轴流风机 EC AXIAL FAN E

COMPANY INTRODUCTION 公司简介

Zhejiang MaEr Fan Motor Co., Ltd., formerly known as Hangzhou MaEr Micro Motor Co., Ltd, is located in Chang'an Town, Haining City, Zhejiang Province, adjacent to the Haining West High-speed Railway Station, and nearby Shanghai-Hangzhou Expressway Chang'an Exit. Founded in 1995, Zhejiang MaEr Fan Motor Co., Ltd., has specialized in manufacturing external-rotor motor fans for approximately 25 years. The YWF series external rotor motor produced by the company has three-phase motor (S type), single-phase capacitor running motor (D type), shaded pole motor, energy-saving EC fan and motor. The rated motor speed is between 500r/min and 3000r/min, while the output power range is between 5w and 3000w, widely used in centrifugal fans and axial fans. With advantages of compact structure, high efficiency, low noise, beautiful appearance, convenient installation and stable operation, The YWF series external rotor axial fans are available in various specifications ranging from Ø175 to Ø900, Which are widely applied in the mechanical equipment, refrigeration equipment and household appliance manufacturing industries.

With the concept of green, environmental protection and low carbon oriented, the company has put into production of a new generation energy-saving motors, fans and EC series. This series applies brushless DC motor drive, which enables the motor higher working efficiency, better speed regulation performance, more safe and reliable speed control, and provides users with more options.

Based on sound quality assurance system and strict quality management measures, the company has achieved the approval of ISO9001:2008 quality management system certification.

In July 2014, Zhejiang MaEr Fan Motor Co., Ltd., successfully entered into joint venture with Zhejiang YILIDA CO.,Ltd, and became a holding subsidiary of Zhejiang YILIDA Group.

Relying on technology as the guidance, quality as the ultimate target, excellent products and good service, Zhejiang MaEr Fan Motor Co., Ltd., is expecting to create the brilliancy together with all new and old clients!



浙江马尔风机有限公司，前身是杭州马尔微电机有限公司，公司坐落于浙江省海宁市长安镇，毗邻高铁海宁西站，沪杭高速长安出口，成立于1995年，有25年生产外转子电机，风机的经验。公司生产的YWF系列外转子电机，有三相电机(S型)，单相电容运转电机(D型),罩极电机，节能型EC风机、电机。电机额定转速从500r/min到3000r/min，输出功率范围5w到3000w，广泛用于离心风机和轴流风机上，公司生产的YWF系列外转子轴流风机的规格从Ø175到Ø900之间的各种规格，产品具有结构紧凑，效率高，噪音低，外形美观，安装方便，产品运行稳定等优点，广泛应用于机械设备，制冷设备及家用电器制造行业中。

公司以绿色，环保，低碳为理念，投产了新一代节能电机，风机，EC系列。该系列应用无刷直流电机驱动，使风机具有更高的工作效率，良好的调速性能，安全可靠的速度控制方法，为用户提供更大的选择余地。

公司生产的电机，风机系列产品获省，市检查优质称号，通过了CCC、CE认证，并取得了全国工业产品生产许可证。

公司通过了ISO9001:2008质量管理体系认证，有完善的质量保证体系和严格的质量保障措施。

公司于2014年7月与浙江亿利达风机股份有限公司合资成功，成为亿利达集团的控股子公司。

公司凭借着以技术为先导，质量为本的宗旨，愿以优秀的产品，良好的服务，与新老客户一起共创辉煌。



BUSINESS NET



- South America:** Brazil, Chile, Colombia, Ecuador, Argentina
- Europe:** Britain, Germany, Italy, Malta, Russia, Spain, Ukraine, France
- Africa:** Egypt, South Africa
- Asia:** Bahrain, India, Indonesia, Israel, Jordan, Kazakhstan, Kuwait, South Korea, Lebanon, Malaysia, Mongolia, Pakistan, Saudi Arabia, Thailand, Turkey
- Oceania:** Australia



MaEr Fan Motor

Professional · Honest · Human Oriented



产品介绍

一、电机型号

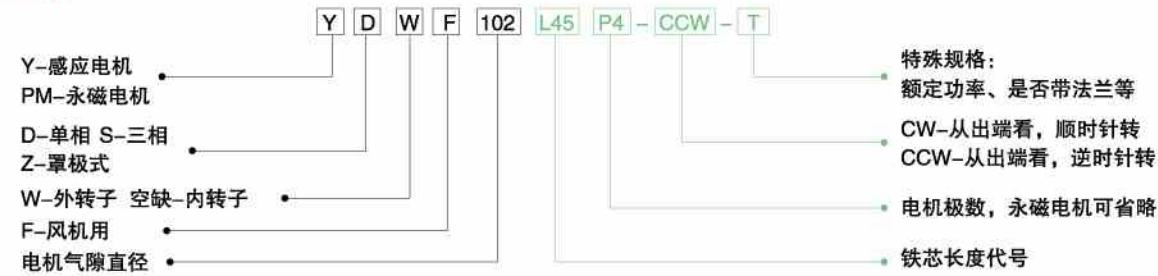

二、外转子轴流风机型号

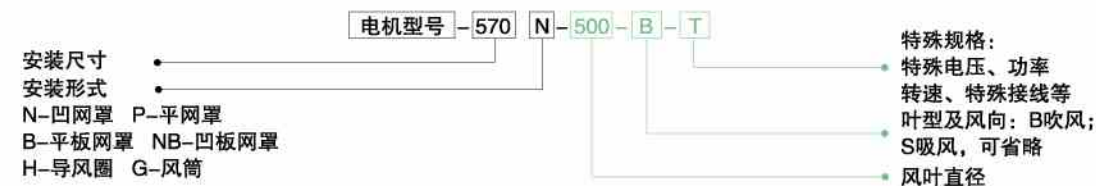

三、罩极式电机

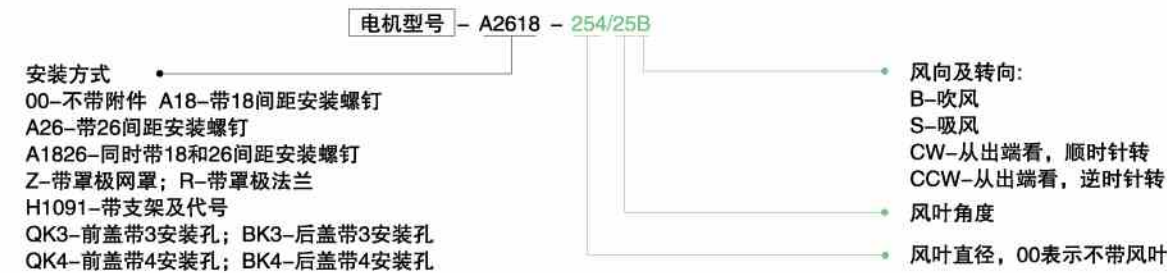

四、电压

单相风机和380V/50Hz三相风机允许工作电压范围为±5%，400V/50Hz三相风机允许工作电压范围为±10%，三相60Hz风机允许工作电压范围为-10%~+20%。

五、风向

轴流风机常规产品为吸风式：空气从风叶经网罩流出。

六、风量曲线

按照GB/T 1236 (IDT ISO 5801)，采用A型风室吸气试验装置，风机运用马尔导风圈并不带防护测得，换算到标准大气压20℃时的性能，所标压力为叶轮静压psf。使用时，静压勿大于对应曲线末端。

七、性能参数

参数表所列参数，为风量曲线测试结果中最高静压效率时的参数，该静压参数下风机在规定的环境温度（热交换空气温度）下长时间运行，若其能效值N>=40，表明该规格风机能效已达到ERP2015；未注能效值N，表明该规格风机无需考核ERP2015。噪声为自由状态时风机出口（45°）1米处的实测值。在非标称电压下，运行参数会略有偏差，以规格书为准。

八、单相电机内均安装有热保护器，其动作温度为B级—130±5℃，F级—150±5℃。三相电机若需安装热保护器，订货时应说明。

九、当客户需对外转子电机进行抽头调速时，为保证低速档的滑差性能要求，高速档的转速和风量相对于常规产品会有所调低。

十、常规产品引出线长度为0.8~1米，特殊长度及装接线盒需特殊说明。

十一、冷风机电机需经特殊工艺处理，以适应低温潮湿环境工作，订货时需说明。

十二、所提供图片和尺寸仅供参考，具体以马尔样机和规格书为准。

MaEr Fan Motor

Professional · Honest · Human Oriented



PRODUCT INTRODUCTION

I. Motor

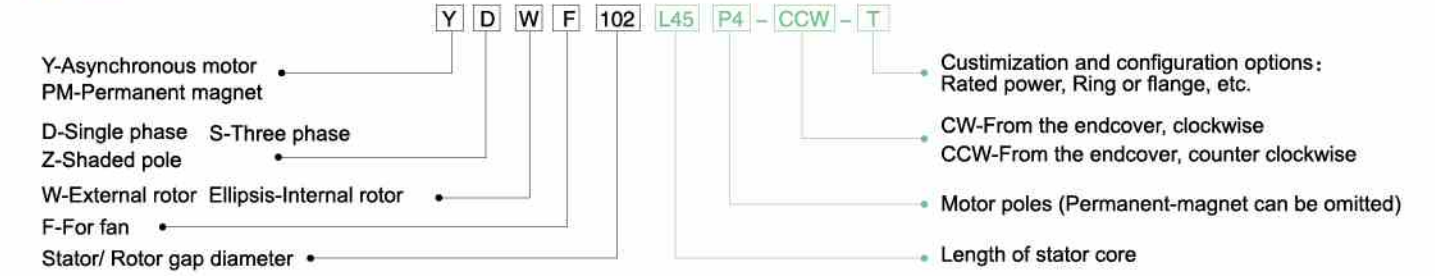

II. Axial fan model

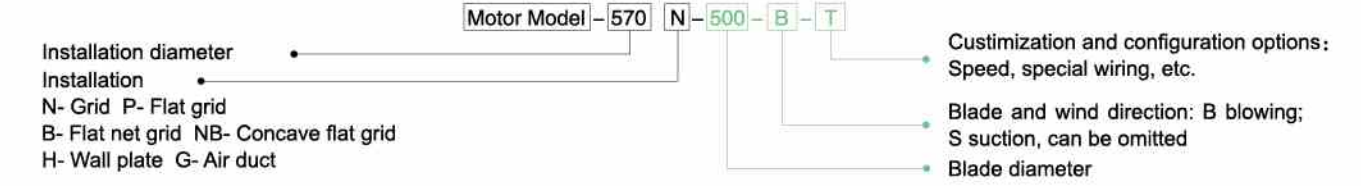

III. Shaded pole motor

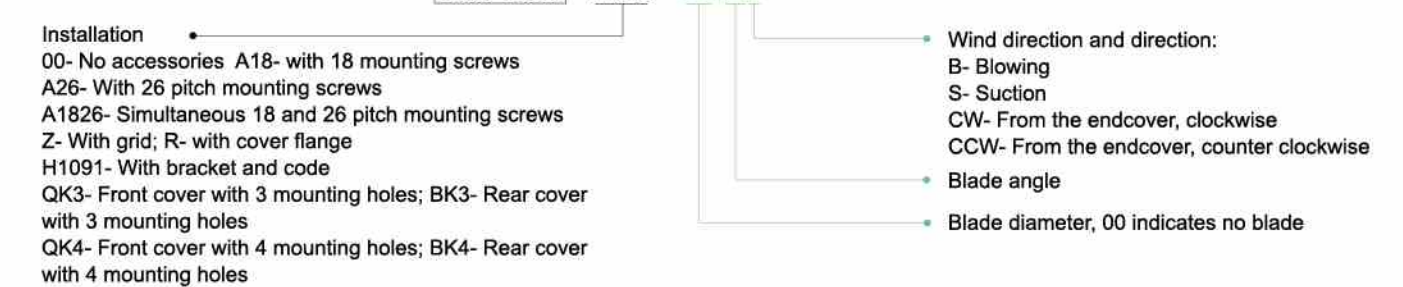

IV. Voltage

The allowed working voltage fluctuation range for single phase fan and 380v/50Hz three phase fan is ±5%，while ±10% for 400v/50Hz three phase fan; the allowed working voltage fluctuation range for 60Hz fan is from -10% to +20%.

V. Airflow direction

The regular product for axial fan is suction type: air flows from the blade through the grid.

VI. Airflow curve

According to GB/T 1236(IDT ISO 5801) and using A type wind room air suction test device. The airflow curve is measured by MaEr wall plate without guard, calculating the performance value under standard atmosphere 20℃. The value here is the impeller static pressure psf. The static pressure should not be higher than the curve end during application.

VII. Performance parameter

The listed parameter is measured at the highest static pressure efficiency, when the fan is able to run for long time under regulated environment temperature. If the energy efficiency value ≥ 40, then the energy efficiency for the fan is ErP 2015. If N is not mentioned, it means this type of fan has no request on ErP 2015. The noise is measured at one meter place from the fan outlet (45°) when it runs freely. But error happens under irregular voltage please refer to the specification.

VIII. Single phase motor is usually equipped with a thermal protector, the operating temperature is level B-130±5℃, level F-150±5℃. If you need to install thermal protector for three phase motor, please specify.

IX. When the client needs to do tapping speed-regulation to the external rotor motor, the max. rotation speed and airflow volume shall be reduced compared with regular products to meet the low speed slip differential performance requirements.

X. The length of the lead wire for regular products is 0.8~1m, special requests on the length and junction box shall be specified.

XI. The cold air blower motor must be processed by special technology to adapt to the low temperature and humidity environment. Please specify when purchasing.

XII. The provided photos and dimensions are for reference only, please refer to the MaEr sample fan and specification for details.

EC35系列节能电机 EC35 SERIES ENERGY SAVING MOTOR

EC35系列节能电机 EC35 SERIES ENERGY SAVING MOTOR



1.型号命名

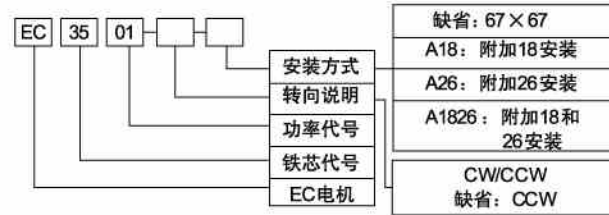

1.MODEL

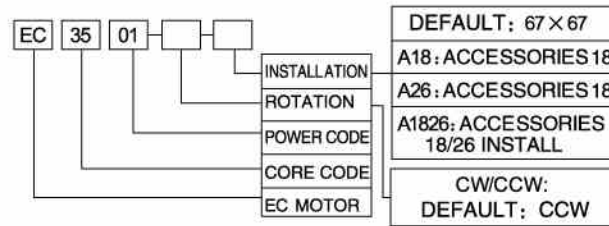

2.整体说明

EC35系列节能电机为塑料外壳的小功率高效永磁无刷电机，防护等级为IP55。电动机具备三种安装方式，适用于替代各罩极电机的安装。主要性能特点是：

- (1) 电动机为采用分数槽技术的三绕组永磁无刷电机，采用矢量控制技术，振动和噪声低，效率超过各国能效要求。
- (2) 电动机采用低噪声滚珠轴承，性能可靠，使用寿命长。
- (3) 电动机具备过压、过流、过热保护功能。
- (4) 电动机具备启动和堵转保护功能。

2.PRODUCTS INTRODUCTION

The EC35 series of energy-saving motors are low-power, plastic shelled, high-efficiency permanent magnet brushless motors with IP55 protection. The motors have three ways to mount. Fit for replacement of kinds of shaded pole motors. The main performance characteristics are:

1. The motor is permanent brushless motor which uses fractal-slot three-winding technology, with Vector control(FOC), low vibration and noise, exceeds various of countries' energy efficiency requirements.
2. The motor uses low-noise ball bearings for reliable performance and long service life.
3. The motor has overvoltage, overcurrent, and overheat protection functions.
4. The motor has start protection and stall protection.

3.外形安装图 INSTALLATION DIAGRAM

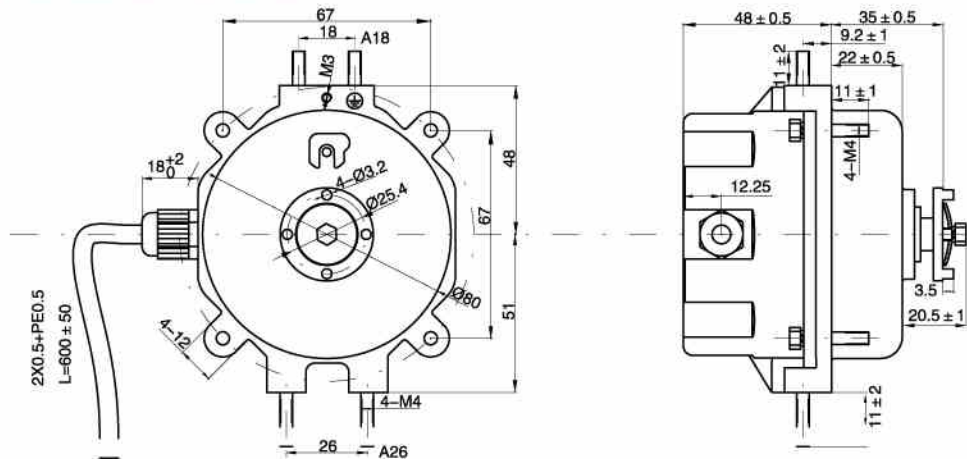

4.口 - 安装附件表 ACCESSORIES

安装代号 Installation code	A18螺栓 A18 bolt	A26螺栓 A26 bolt	网罩 Grid	法兰 Ring	支架 Bracket
00	—	—	—	—	—
A18	2-M4X14	—	—	—	—
A26	—	2-M4X14	—	—	—
A1826	2-M4X14	2-M4X14	—	—	—
***Z	—	—	选配 Optional	—	—
***R	—	—	—	选配 Optional	—
H***	选配 Optional	选配 Optional	—	—	选配 Optional

5.风叶配合运行参数 ALUMINUM BLADE PARAMETER

型号 MODEL	电压 UAC	频率 f	曲线 CURVE	输出功率 P1	转速 n	电流 I	静压 Psf	环境温度 Temp.
	V	Hz	NO.	W	r/min	A	Pa	°C
EC3502B-□-172/28*	230±10%	50/60	A	9	1800	0.08	28	-40~+50
EC3502B-□-200/28*	230±10%	50/60	B	9	1410	0.08	22	-40~+50
EC3502B-□-200/31*	230±10%	50/60	C	13	1800	0.11	25	-40~+50
EC3502B-□-200/31*	230±10%	50/60	D	11	1410	0.10	20	-40~+50
EC3502B-□-200/31*	230±10%	50/60	E	17	1800	0.14	29	-40~+50
EC3502B-□-200/34*	230±10%	50/60	F	11	1410	0.09	17	-40~+50
EC3502B-□-200/34*	230±10%	50/60	G	16	1800	0.13	25	-40~+50
EC3502B-□-230/28*	230±10%	50/60	H	17	1410	0.15	25	-40~+50
EC3502B-□-230/31*	230±10%	50/60	I	19	1550	0.15	34	-40~+50
EC3502B-□-230/31*	230±10%	50/60	J	23	1410	0.18	25	-40~+50
EC3502B-□-230/34*	230±10%	50/60	K	22	1550	0.18	30	-40~+50
EC3502B-□-230/34*	230±10%	50/60	L	25	1410	0.19	24	-40~+50
EC3502B-□-230/34*	230±10%	50/60	M	27	1550	0.21	35	-40~+50
EC3502B-□-254/25*	230±10%		N	18	1410	0.16	25	-40~+50
EC3502B-□-254/25*	230±10%		P	17	1550	0.14	26	-40~+50
EC3502B-□-254/28*	230±10%		Q	28	1360	0.21	27	-40~+50
EC3502B-□-254/28*	230±10%		R	28	1550	0.21	34	-40~+50
EC3502B-□-254/34*	230±10%		S	28	1330	0.21	25	-40~+50
EC3502B-□-254/34*	230±10%		T	28	1550	0.21	28	-40~+45
EC3502B-□-300/22*	230±10%		U	28	1300	0.21	19	-40~+45
EC3502B-□-300/22*	230±10%		V	37	1550	0.27	30	-40~+45
EC3502B-□-300/25*	230±10%		W	29	1250	0.21	11	-40~+40
EC3502B-□-300/25*	230±10%		X	36	1550	0.27	32	-40~+40

*注：风向标记，B--吹风，S--吸风。*Note: air flow direction, B - Blowing, S - Suction.

□注：安装代号，见附表。□Note: Installation code, see : Accessories

MaEr Fan Motor

Professional · Honest · Human Oriented



Material:	Impeller: Completely made of aluminum alloy;
Type of protection:	IP65
Mounting position:	Horizontal or vertical
Operation Mode:	S1
Bearings:	Maintenance-free ball bearings
Protection:	Current limitation, Stall protection, Soft start phase failure detection, Overheat protection, Over/ Under voltage protection
EMC:	According to EN61000-6-3/2, EN61000-3-2/3, CCC, CE
Amb.Temp:	-40~+65°C
Insulation class:	F

材料:	风叶-采用铝镁合金制成
电机防护等级:	IP65
安装位置:	竖直、水平线2个方向
连续工作制:	(S1)
轴承:	免维护轴承
保护:	限流、堵转、软启动、缺相故障、热保护、过/欠压保护
EMC:	符合EN61000-6-3/2, EN61000-3-2/3, CCC、CE认证
环境温度:	-40~+65°C
绝缘等级:	F

MaEr Fan Motor

Professional · Honest · Human Oriented



EC35曲线 EC35 CURVE

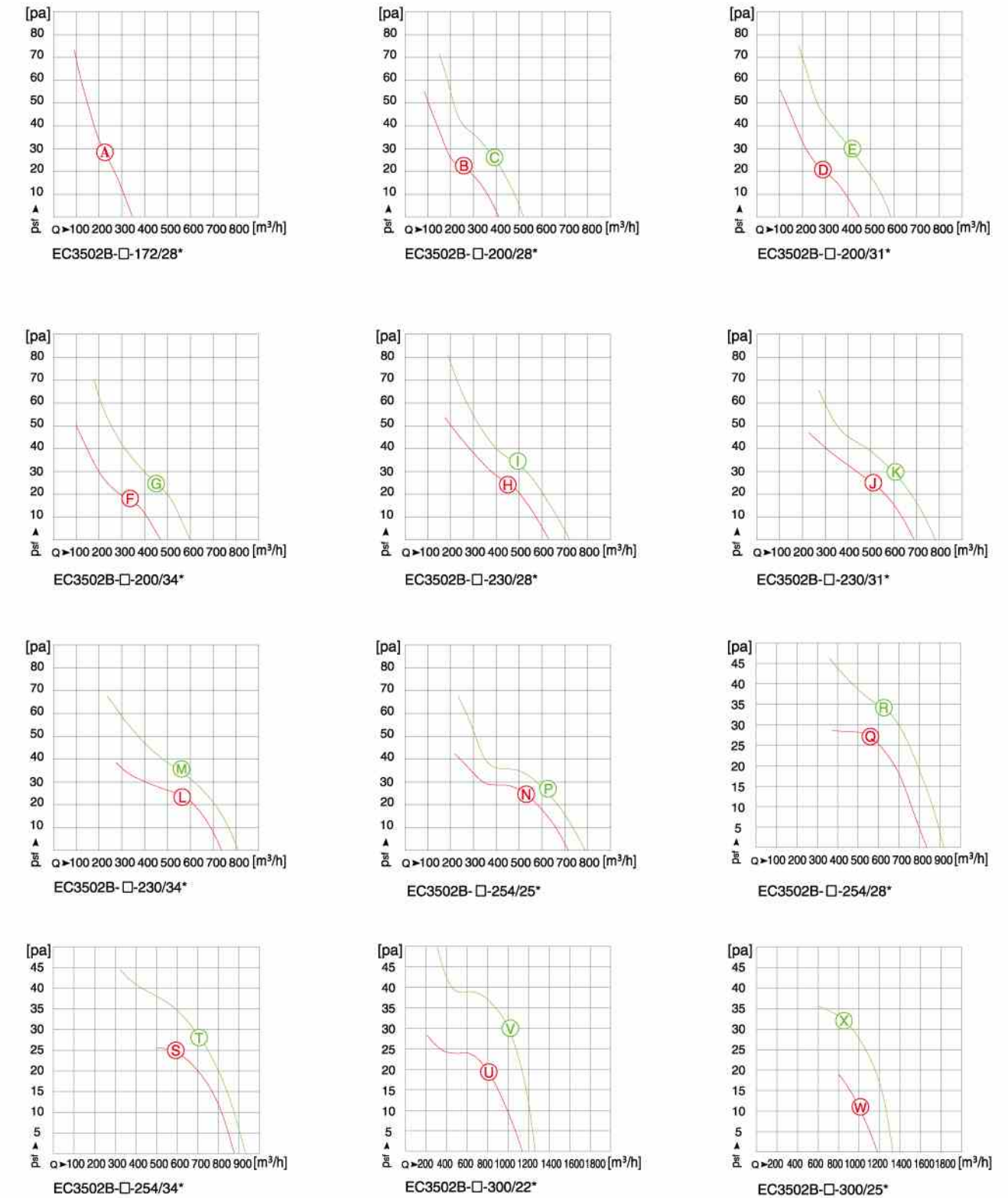

MaEr Fan Motor

Professional · Honest · Human Oriented



EC AXIAL FAN
EC外转子轴流风机

1-230V EC074电机

MaEr Fan Motor

Professional · Honest · Human Oriented



074-230V SERIES MOTOR WIRING INSTRUCTION

074电机系列接线说明图

Wiring diagram 接线标识图

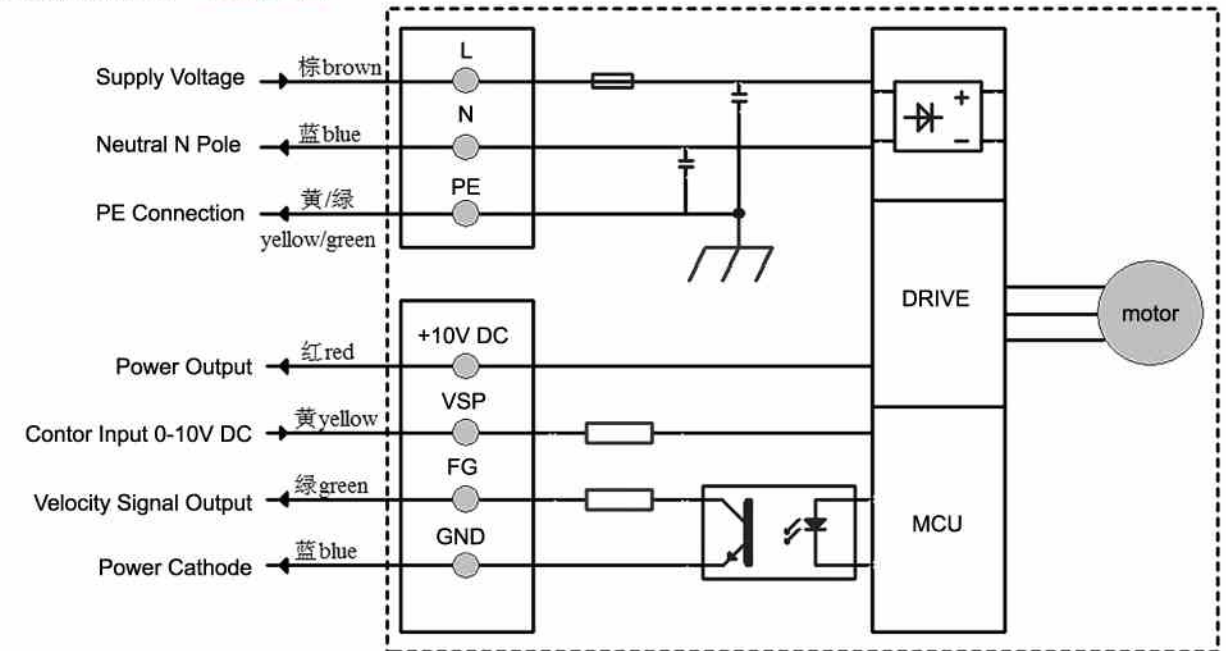

Portal function 接线端口功能说明图

序号	信号	分配/功能	序号	信号	分配/功能
P1	L	交流电接入, 供给电压1~207-277V AC; 频率50/60Hz	P2	GND	接口P2控制信号地
	N	交流电接入, 中性线N极		0~10V/PWM	控制输入0~10V DC/PWM
	PE	接地线, PE连接		FG	速度反馈信号
				10V	固定电压输出10V DC (±10%最大.10mA)

HUB	Portal	Description/Function	HUB	Portal	Description/Function
P1	L	AC power in, Voltage Input 1~207-277V; 50/60Hz	P2	GND	Interface P3 for Signal Control, Ground
	N	AC Power in, Neutral N Pole		0~10V/PWM	Controller Input 0~10V DC/PWM
	PE	Protect Earthing, Ground		FG	Speed Signal Feedback
				10V	Rated Voltage Output 10V DC (±10% max. 10mA)

MaEr Fan Motor

Professional · Honest · Human Oriented



Ø 300 EC AXIAL FAN EC 外转子轴流风机

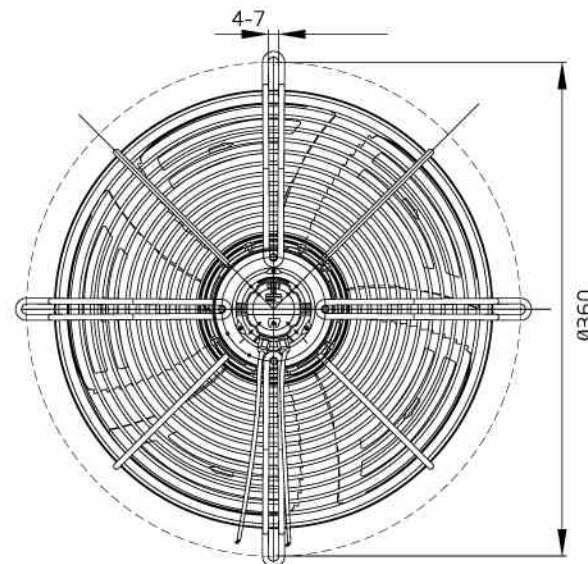
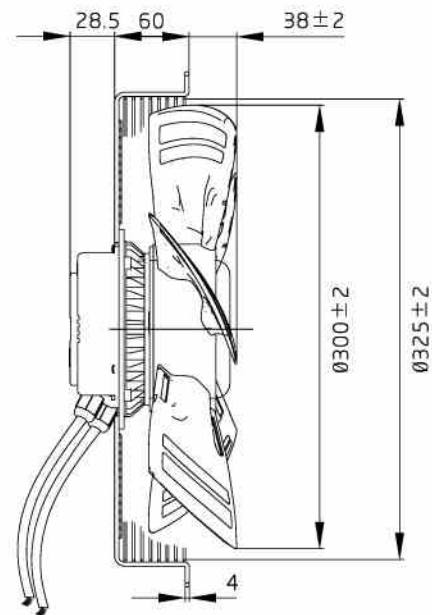
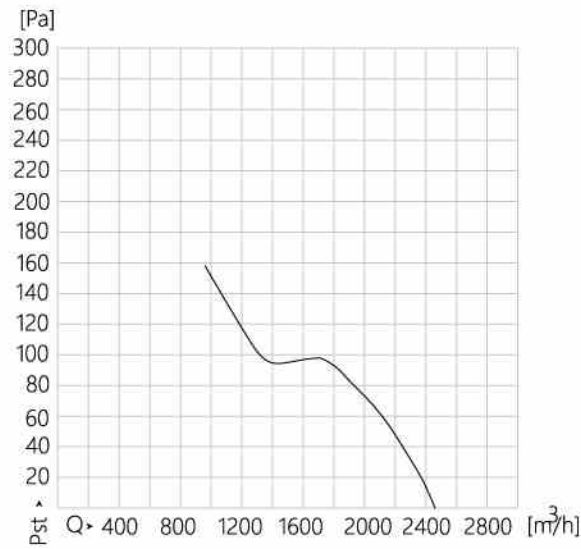

MaEr Fan Motor

Professional · Honest · Human Oriented



型号	电压	频率	功率	风量	电流	转速	噪音
MODEL	Voltage	Frequency	Power	Airflow	Current	RPM	Noise
	V	Hz	W	m³/h	A	r/min	dB(A)
PMDWF74L25P8-360P-300	1~230	50/60	141	2460	0.96	2100	65

注：性能曲线在安装马尔导风圈时测得。Note: The performance curve is tested with MaEr wall plate.

Material:	Blade: PP+40%GF; Rotor: Coated in black; Electronics enclosure: Die-cast aluminum
Fan blade:	5-pack
Direction of rotation:	Counter clockwise, view from end cover
Type of protection:	IP54
Mounting position:	Horizontal or Vertical
Operation Mode:	S1
Bearings:	Maintenance-free ball bearings
Technical features:	Control input 0~10V DC/PWM; Integrated PID controller; Speed signal feedback Single auxiliary output power supply: 10V DC±10%, max. 10mA
Protection:	Current limitation, Stall protection, Soft start protection, Open phase protection, Overheating protection, Over/ Under voltage protection
EMC:	According to EN61000-6-3/2, EN61000-3-2/3
Approvals:	CCC, CE
Amb.Temp:	-25~+60°C
Insulation class:	F
材料:	风轮-PP+40%GF; 转子-镀黑; 电气罩-压铸铝
叶片数:	5
从引出线端看为:	逆时针
电机防护等级:	IP54
安装位置:	竖直、水平线2个方向
连续工作制:	(S1)
轴承:	免维护轴承
电气特性:	控制信号输入: 0~10V DC/PWM; 集成PID调节; 速度反馈信号 单路辅助电源: 10V DC±10%, max.10mA
保护:	限流、堵转、软启动、缺相故障、过温保护、过/欠压保护
EMC:	符合EN61000-6-3/2, EN61000-3-2/3
证书:	CCC、CE认证
环境温度:	-25~+60°C
绝缘等级:	F

MaEr Fan Motor

Professional · Honest · Human Oriented



Ø 350 EC AXIAL FAN EC 外转子轴流风机

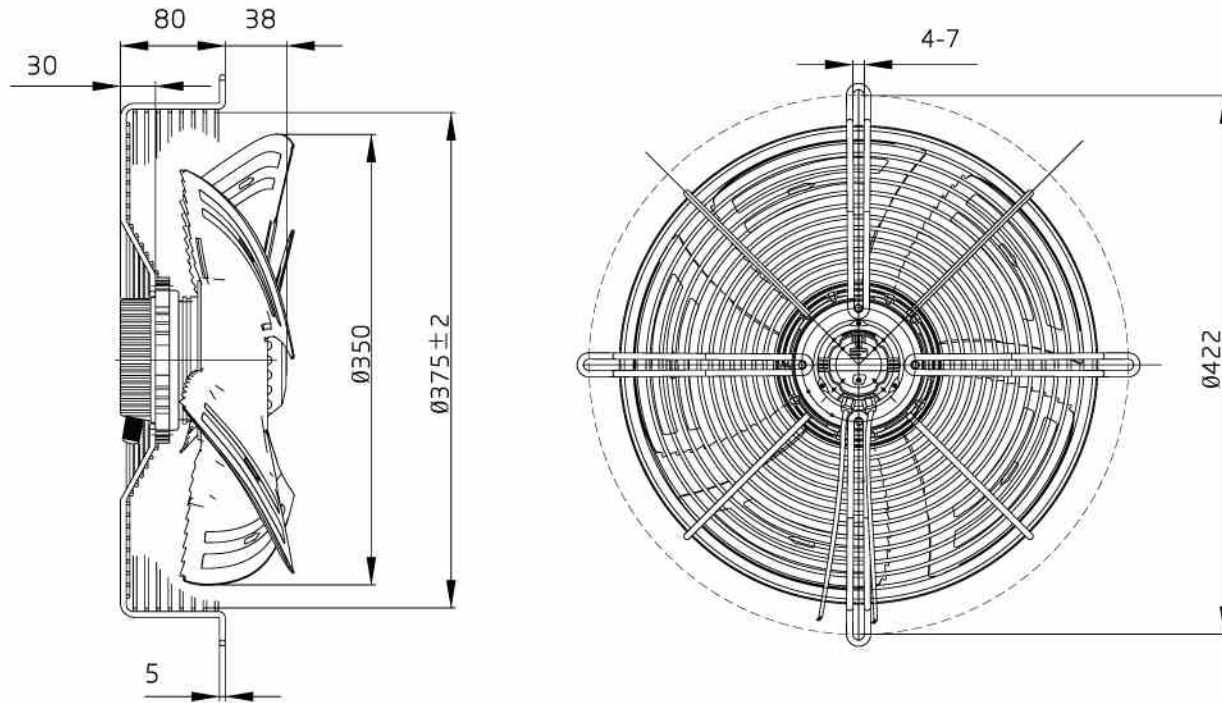
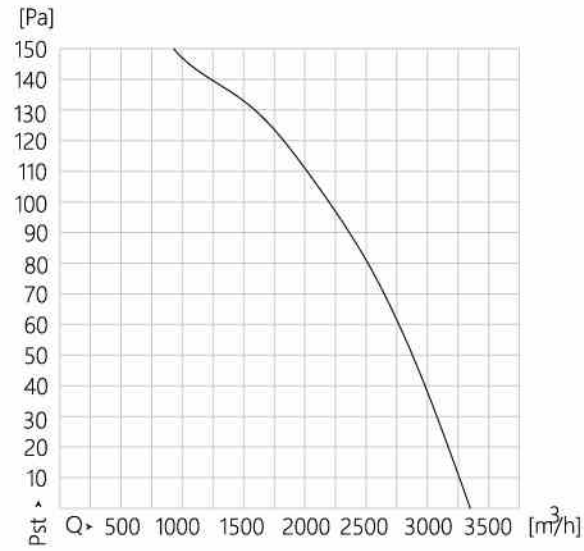

MaEr Fan Motor

Professional · Honest · Human Oriented



型号	电压	频率	功率	风量	电流	转速	噪音
MODEL	Voltage	Frequency	Power	Airflow	Current	RPM	Noise
	V	Hz	W	m³/h	A	r/min	dB(A)
PMDWF74L25P8-422N-350	1~230	50/60	156	3360	1.07	1600	67

注：性能曲线在安装马尔导风扇圈时测得。 Note: The performance curve is tested with MaEr wall plate.

Material:	Blade: PP+40%GF; Rotor: Coated in black; Electronics enclosure: Die-cast aluminum
Fan blade:	5-pack
Direction of rotation:	Counter clockwise, view from end cover
Type of protection:	IP54
Mounting position:	Horizontal or Vertical
Operation Mode:	S1
Bearings:	Maintenance-free ball bearings
Technical features:	Control input 0~10V DC/PWM; Integrated PID controller; Speed signal feedback Single auxiliary output power supply: 10V DC±10%, max. 10mA
Protection:	Current limitation, Stall protection, Soft start protection, Open phase protection, Overheating protection, Over/ Under voltage protection
EMC:	According to EN61000-6-3/2, EN61000-3-2/3
Approvals:	CCC, CE
Amb.Temp:	-25~+60°C
Insulation class:	F

材料:	风轮-PP+40%GF; 转子-镀黑; 电气罩-压铸铝
叶片数:	5
从引出线端看为:	逆时针
电机防护等级:	IP54
安装位置:	竖直、水平线2个方向
连续工作制:	(S1)
轴承:	免维护轴承
电气特性:	控制信号输入: 0~10V DC/PWM; 集成PID调节; 速度反馈信号 单路辅助电源: 10V DC±10%, max.10mA
保护:	限流、堵转、软启动、缺相故障、过温保护、过/欠压保护
EMC:	符合EN61000-6-3/2, EN61000-3-2/3
证书:	CCC、CE认证
环境温度:	-25~+60°C
绝缘等级:	F



EC AXIAL FAN EC外转子轴流风机

1-230V EC084电机

084-230V SERIES MOTOR WIRING INSTRUCTION

084电机系列接线说明图

Wiring indication 接线标识图

P1				P2			P3				
GND	0~10V	FG	10V	NO	COM	NC	L		N		PE

Portal function 接线端口功能说明图

序号	信号	分配/功能	序号	信号	分配/功能
PE	PE(黄/绿)	接地线, PE连接		10V(红)	固定电压输出10VDC (+10%最大.10mA)
P1	N (蓝)	交流电接入, 中性线N极	P3	FG(绿)	速度反馈信号
	L(棕)	交流电接入, 供给电压1~207-277VAC;频率50/60Hz		0~10V/PWM(黄)	控制输入0~10VDC/PWM
P2	NO(橙)	状态继电器, 浮动状态触点; 常开; 关闭错误		GND(蓝)	接口P3控制信号地
	COM(灰)	状态继电器, 公共连接; 连接等级250VAC/2A			
	NC(白)	状态继电器, 常闭, 解除错误			

HUB	Portal	Description/Function	HUB	Portal	Description/Function
PE	PE (Yellow/Green)	Earth connection, PE connection	P3	10V (Red)	Rated voltage output 10V DC (±10% max. 10mA)
	P1	N (Blue)		AC power in, Neutral N pole	FG (Green)
	L (Brown)	AC power in, 1~207-277V AC; 50/60Hz		0~10V/PWM (Yellow)	Control input 0~10V DC/PWM
P2	NO (Orange)	Status relay, Floating status contact; make for failure	GND (Blue)	Interface P3 for signal control, ground	
	COM (Gray)	Status relay, common connection; contact reating 250V AC/2A			
	NC (White)	Status relay, normally closed, break for failure			

MaEr Fan Motor

Professional · Honest · Human Oriented



Ø 400 EC AXIAL FAN EC 外转子轴流风机

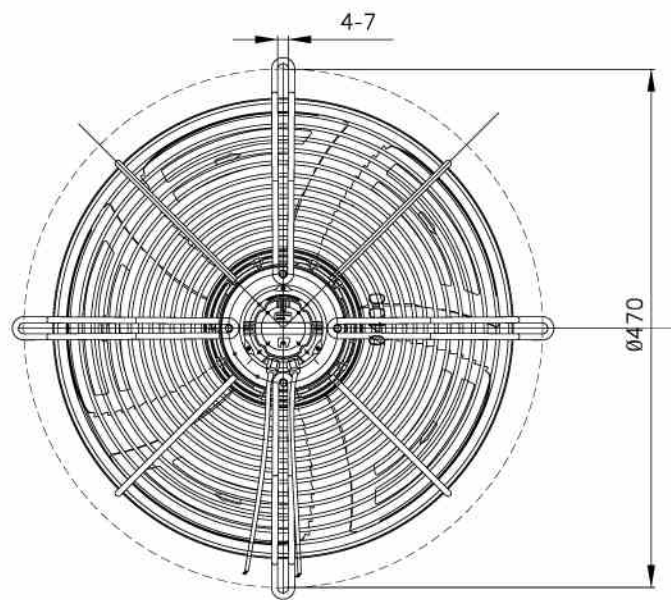
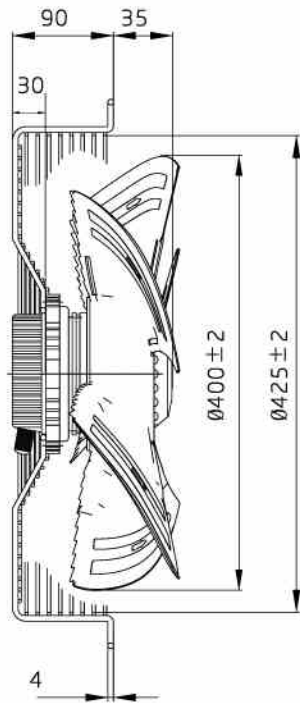
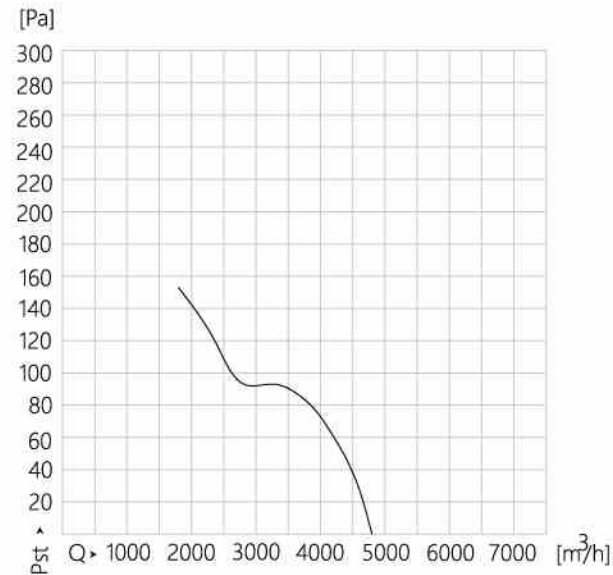

MaEr Fan Motor

Professional · Honest · Human Oriented



型号	电压	频率	功率	风量	电流	转速	噪音
MODEL	Voltage	Frequency	Power	Airflow	Current	RPM	Noise
	V	Hz	W	m³/h	A	r/min	dB(A)
PMDWF84L50-470N-400	1 ~ 230	50/60	364	4806	1.58	1600	70

注：性能曲线在安装马尔导风圈时测得。 Note: The performance curve is tested with MaEr wall plate.

Material:	Impeller: ABS; Rotor: Coated in black; Electronics enclosure: Die-cast aluminum
Fan blade:	5-pack
Direction of rotation:	Counter clockwise, view from end cover
Type of protection:	IP54
Mounting position:	Horizontal or Vertical
Operation Mode:	S1
Bearings:	Maintenance-free ball bearings
Technical features:	Control input 0~10V DC/PWM; PFC (active); Integrated PID controller; Speed signal feedback; Relay Single auxiliary output power supply: 10V DC±10%, max.10mA
Protection:	Current limitation, Stall protection, Soft start protection, Open phase protection, Overheating protection, Over/ Under voltage protection
EMC:	According to EN61000-6-3/2, EN61000-3-2/3
Approvals:	CCC, CE
Amb.Temp:	-25~+60°C
Insulation class:	F

材料:	风轮-ABS; 转子-镀黑; 电气罩-压铸铝
叶片数:	5
从引出线端看为:	逆时针
电机防护等级:	IP54
安装位置:	竖直、水平线2个方向
连续工作制:	(S1)
轴承:	免维护轴承
电气特性:	控制信号输入: 0~10V DC/PWM; 含主动式PFC电路; 集成PID调节; 速度反馈信号; 报警信号继电器 单路辅助电源: 10V DC±10%, max.10mA
保护:	限流、堵转、软启动、缺相故障、过温保护、过/欠压保护
EMC:	符合EN61000-6-3/2, EN61000-3-2/3
证书:	CCC、CE认证
环境温度:	-25~+60°C
绝缘等级:	F

MaEr Fan Motor

Professional · Honest · Human Oriented



Ø 450 EC AXIAL FAN EC 外转子轴流风机

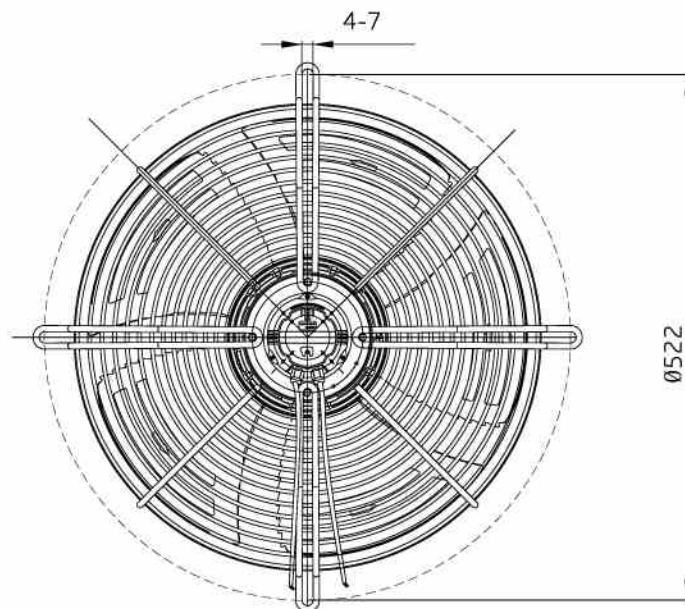
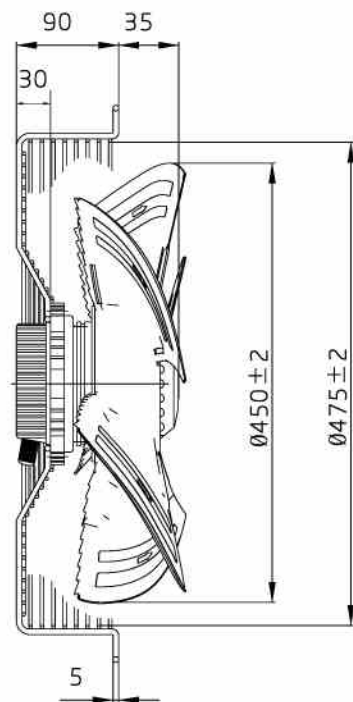
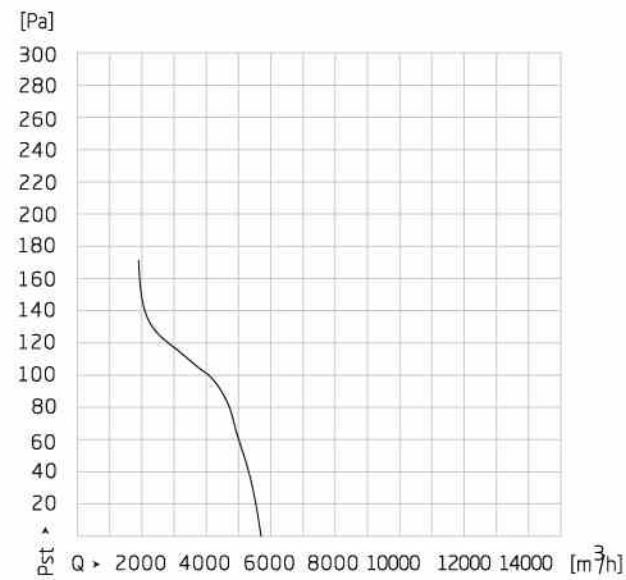

MaEr Fan Motor

Professional · Honest · Human Oriented



型号	电压	频率	功率	风量	电流	转速	噪音
MODEL	Voltage	Frequency	Power	Airflow	Current	RPM	Noise
	V	Hz	W	m³/h	A	r/min	dB(A)
PMDWF84L50-522N-450	1 ~ 230	50/60	387	5719	1.76	1500	70

注：性能曲线在安装马尔导风扇时测得。Note: The performance curve is tested with MaEr wall plate.

Material:	Impeller: ABS; Rotor: Coated in black; Electronics enclosure: Die-cast aluminum
Fan blade:	5-pack
Direction of rotation:	Counter clockwise, view from end cover
Type of protection:	IP54
Mounting position:	Horizontal or Vertical
Operation Mode:	S1
Bearings:	Maintenance-free ball bearings
Technical features:	Control input 0~10V DC/PWM; PFC (active); Integrated PID controller; Speed signal feedback; Relay Single auxiliary output power supply: 10V DC±10%, max.10mA
Protection:	Current limitation, Stall protection, Soft start protection, Open phase protection, Overheating protection, Over/ Under voltage protection
EMC:	According to EN61000-6-3/2, EN61000-3-2/3
Approvals:	CCC, CE
Amb.Temp:	-25~+60°C
Insulation class:	F

材料:	风轮-ABS; 转子-镀黑; 电气罩-压铸铝
叶片数:	5
从引出线端看为:	逆时针
电机防护等级:	IP54
安装位置:	竖直、水平2个方向
连续工作制:	(S1)
轴承:	免维护轴承
电气特性:	控制信号输入: 0~10V DC/PWM; 含主动式PFC电路; 集成PID调节; 速度反馈信号; 报警信号继电器 单路辅助电源: 10V DC±10%, max.10mA
保护:	限流、堵转、软启动、缺相故障、过温保护、过/欠压保护
EMC:	符合EN61000-6-3/2, EN61000-3-2/3
证书:	CCC、CE认证
环境温度:	-25~+60°C
绝缘等级:	F

MaEr Fan Motor

Professional · Honest · Human Oriented



EC AXIAL FAN
EC外转子轴流风机

3-400V EC112电机

MaEr Fan Motor

Professional · Honest · Human Oriented



112-400V SERIES MOTOR WIRING INSTRUCTION 112电机系列接线说明图

Wiring indication 接线标识图

P3								P2			P1			
RSA	RSB	4~20mA	20V	10V	0~10V	GND	FG	NO	COM	NC	L3	L2	L1	PE

Portal function 接线端口功能说明图

序号	信号	分配/功能	序号	信号	分配/功能
	L3	交流电接入, 供给电压3~380-480VAC;频率50/60Hz		RSA	RS485总线连接; RSA;MODBUS通讯协议RTU方式
P1	L2	交流电接入, 供给电压3~380-480VAC;频率50/60Hz		RSB	RS485总线连接; RSB;MODBUS通讯协议RTU方式
	L1	交流电接入, 供给电压3~380-480VAC;频率50/60Hz		GND	接口P3控制信号地
PE	PE	接地线, PE连接	P3	0~10V/PWM	控制输入0~10VDC/PWM
	NO	状态继电器, 浮动状态触点; 常开; 关闭错误		4~20mA	控制输入 4~20mA
P2	COM	状态继电器, 公共连接; 连接等级250VAC/2A		20V	固定电压输出20VDC (±10%最大.50mA)
	NC	状态继电器, 常闭, 解除错误		10V	固定电压输出10VDC (±10%最大.10mA)
				FG	速度反馈信号

HUB Portal	Description/Function	HUB Portal	Description/Function
L3	AC power in, voltage input 3~380-480V; 50/60Hz	RSA	Bus RS485; RSA; MODBUS RTU
P1 L2	AC power in, voltage input 3~380-480V; 50/60Hz	RSB	Bus RS485; RSA; MODBUS RTU
L1	AC power in, voltage input 3~380-480V; 50/60Hz	GND	Interface P3 for signal control, ground
PE PE	Protect earthing, ground	0~10V/PWM	Controller input 0~10V DC/PWM
	State relay, alterable state contact; normally turn-on; turn-off when error	P3 4~20mA	Analogue Control input 4~20mA
P2 COM	State relay, universal connectivity; contact rating 250V AC/2A	20V	Rated voltage output 20VDC (±10% max. 50mA)
	State relay, normally turn-off, turn-on when error	10V	Rated voltage output 10VDC (±10% max. 10mA)
		FG	Speed Signal Feedback

MaEr Fan Motor

Professional · Honest · Human Oriented



Ø 500 EC AXIAL FAN EC 外转子轴流风机

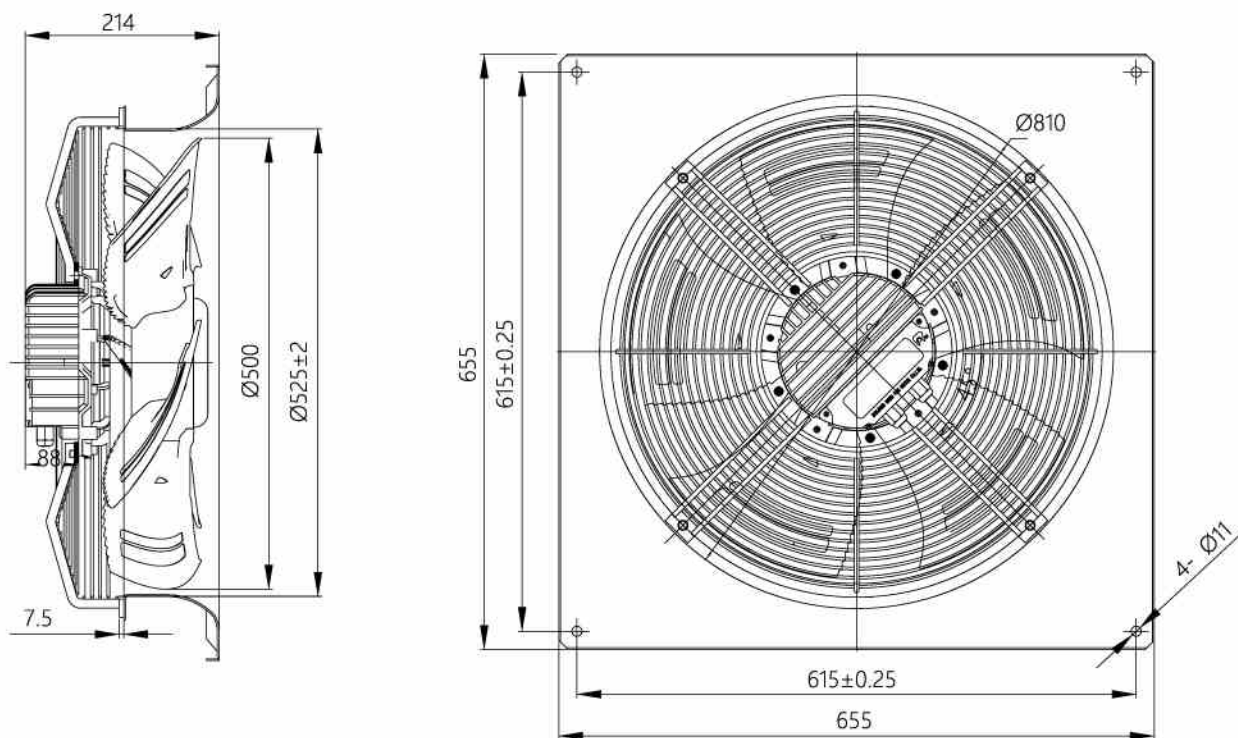
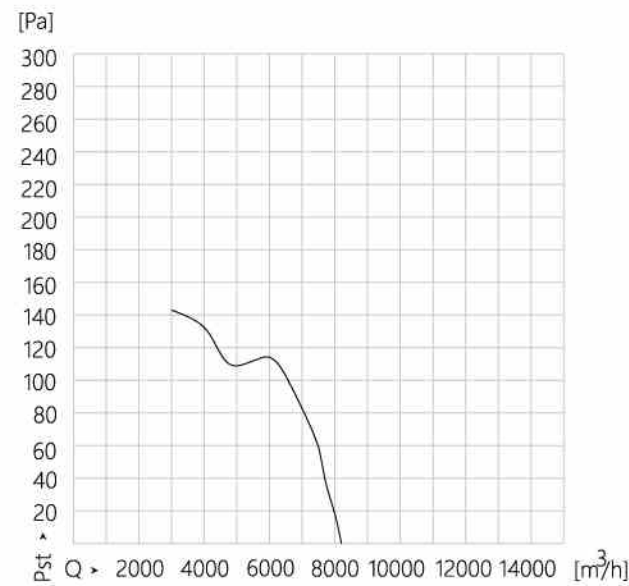

MaEr Fan Motor

Professional · Honest · Human Oriented



型号	电压	频率	功率	风量	电流	转速	噪音
MODEL	Voltage	Frequency	Power	Airflow	Current	RPM	Noise
	V	Hz	W	m³/h	A	r/min	dB(A)
PMSWF112L60-615H-500	3 ~ 400	50/60	566	8222	1.00	1400	78

注：性能曲线在安装马尔导风扇时测得。 Note: The performance curve is tested with MaEr wall plate.

Material:	Impeller: ABS; Rotor: Coated in black; Electronics enclosure: Die-cast aluminum
Fan blade:	5-pack
Direction of rotation:	Counter clockwise, view from end cover
Type of protection:	IP54
Mounting position:	Horizontal or Vertical
Operation Mode:	S1
Bearings:	Maintenance-free ball bearings
Technical features:	Control input: 0~10V DC/PWM; Current input control: 4-20mA; 20v DC±10%, max. 50mA Integrated PID controller; Speed signal feedback; relay Dual auxiliary output power supplies: 10V DC±10%, max.10mA
Protection:	Current limitation, Stall protection, Soft start protection, Open phase protection, Overheating protection, Over/ Under voltage protection
EMC:	According to EN61000-6-3/2, EN61000-3-2/3
Approvals:	CCC, CE
Amb.Temp:	-40~+65 °C
Insulation class:	F
材料:	风轮-ABS; 转子-镀黑; 电气罩-压铸铝
叶片数:	5
电机防护等级:	逆时针
从引出线端看为:	IP54
安装位置:	竖直、水平2个方向
连续工作制:	(S1)
轴承:	免维护轴承
电气特性:	控制信号输入: 0~10V DC/PWM; 电流控制: 4-20mA; 集成PID调节; 速度反馈信号; 报警信号继电器 双路辅助电源: 10V DC±10%, max.10mA; 20v DC±10%, max.50mA
保护:	限流、堵转、软启动、缺相故障、过温保护、过/欠压保护
EMC:	符合EN61000-6-3/2, EN61000-3-2/3
证书:	CCC、CE认证
环境温度:	-40~+65°C
绝缘等级:	F

MaEr Fan Motor

Professional · Honest · Human Oriented



Ø 630 EC AXIAL FAN EC 外转子轴流风机

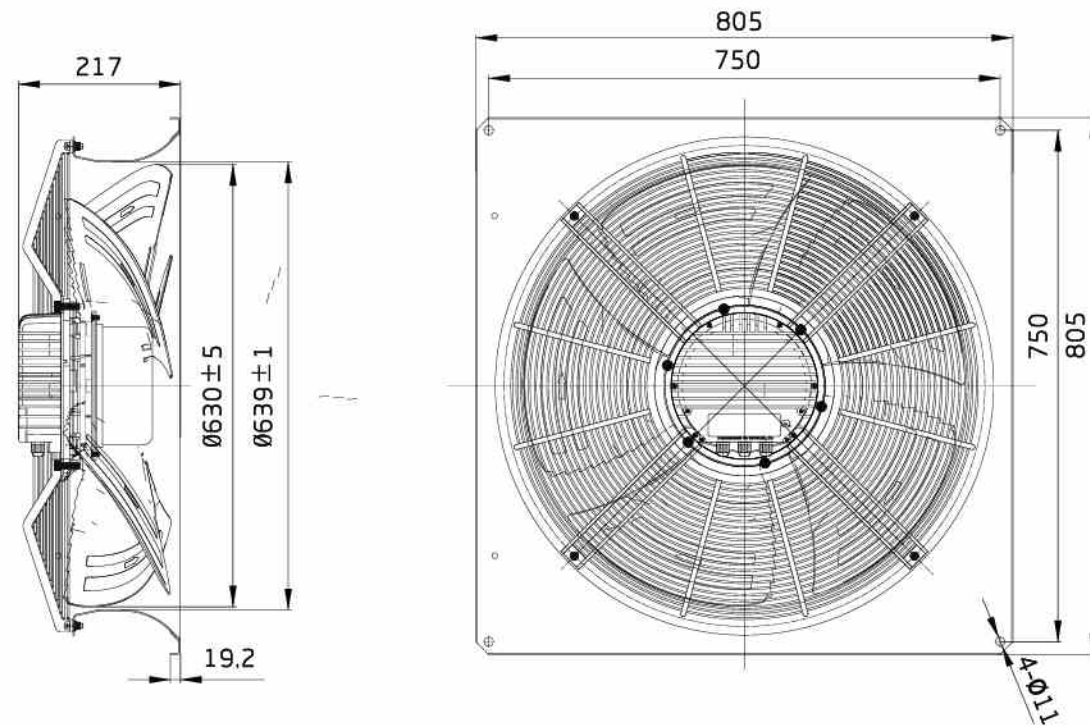
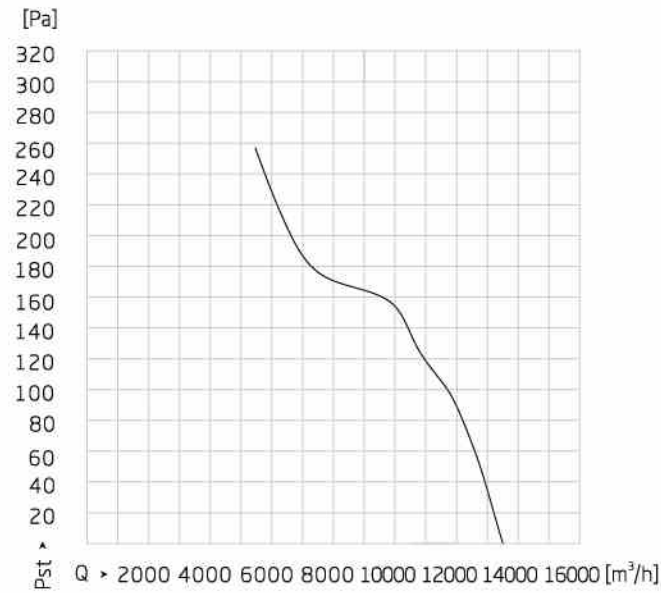

MaEr Fan Motor

Professional · Honest · Human Oriented



型号	电压	频率	功率	风量	电流	转速	噪音
MODEL	Voltage	Frequency	Power	Airflow	Current	RPM	Noise
	V	Hz	W	m³/h	A	r/min	dB(A)
PMSWF112L60-750H-630	3~400	50/60	900	13464	1.60	1200	74

注：性能曲线在安装马尔导风圈时测得。 Note: The performance curve is tested with MaEr wall plate.

Material:	Impeller: ABS; Rotor: Coated in black; Electronics enclosure: Die-cast aluminum
Fan blade:	5-pack
Direction of rotation:	Counter clockwise, view from end cover
Type of protection:	IP54
Mounting position:	Horizontal or Vertical
Operation Mode:	S1
Bearings:	Maintenance-free ball bearings
Technical features:	Control input: 0~10V DC/PWM; Current input control: 4-20mA; 20v DC±10%, max. 50mA Integrated PID controller; Speed signal feedback; relay Dual auxiliary output power supplies: 10V DC±10%, max.10mA
Protection:	Current limitation, Stall protection, Soft start protection, Open phase protection, Overheating protection, Over/ Under voltage protection
EMC:	According to EN61000-6-3/2, EN61000-3-2/3
Approvals:	CCC, CE
Amb.Temp:	-40~+65 °C
Insulation class:	F
材料:	风轮-ABS; 转子-镀黑; 电气罩-压铸铝
叶片数:	5
电机防护等级:	逆时针
从引出线端看为:	IP54
安装位置:	竖直、水平线2个方向
连续工作制:	(S1)
轴承:	免维护轴承
电气特性:	控制信号输入: 0~10V DC/PWM; 电流控制: 4-20mA; 集成PID调节; 速度反馈信号; 报警信号继电器 双路辅助电源: 10V DC±10%, max.10mA; 20v DC±10%, max.50mA
保护:	限流、堵转、软启动、缺相故障、过温保护、过/欠压保护
EMC:	符合EN61000-6-3/2, EN61000-3-2/3
证书:	CCC、CE认证
环境温度:	-40~+65°C
绝缘等级:	F

MaEr Fan Motor

Professional · Honest · Human Oriented



Ø 710 EC AXIAL FAN EC 外转子轴流风机

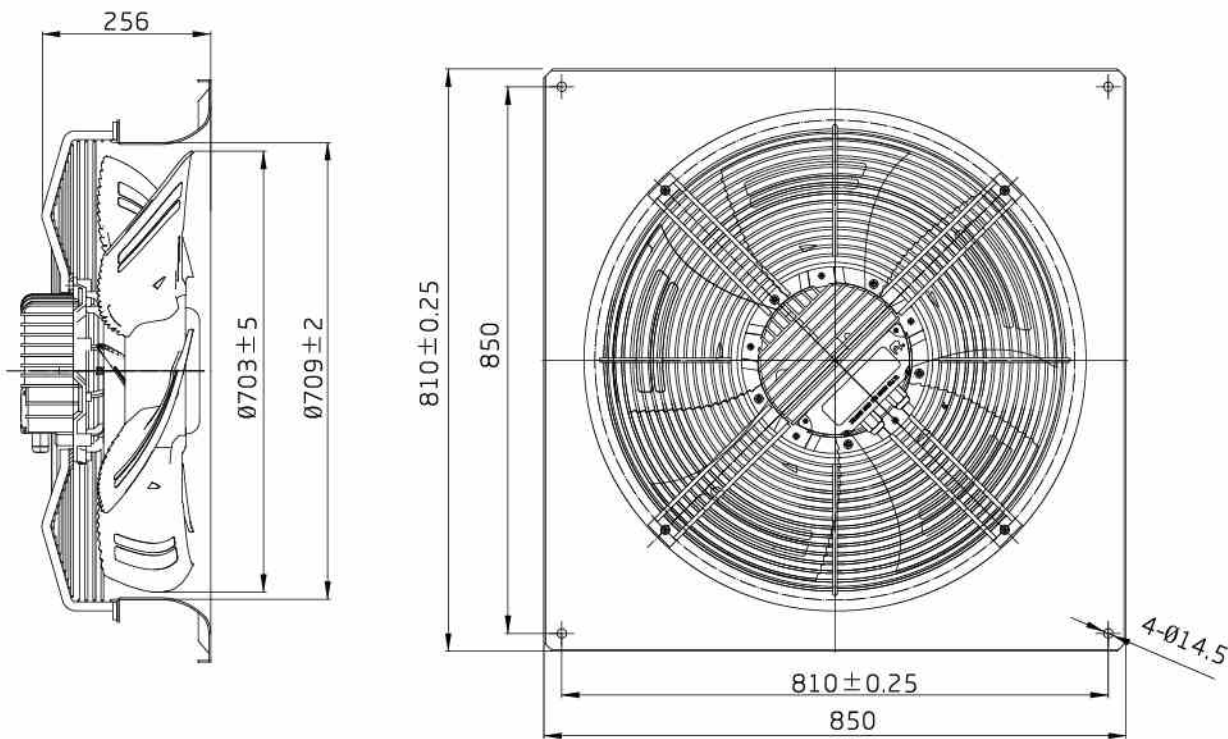
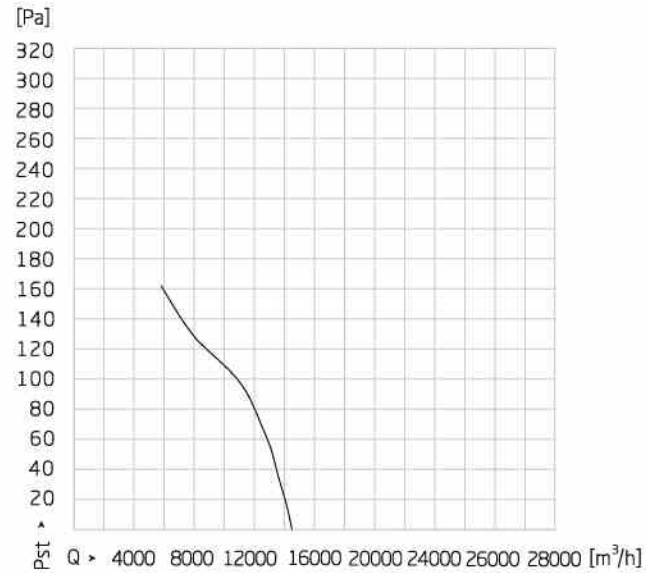
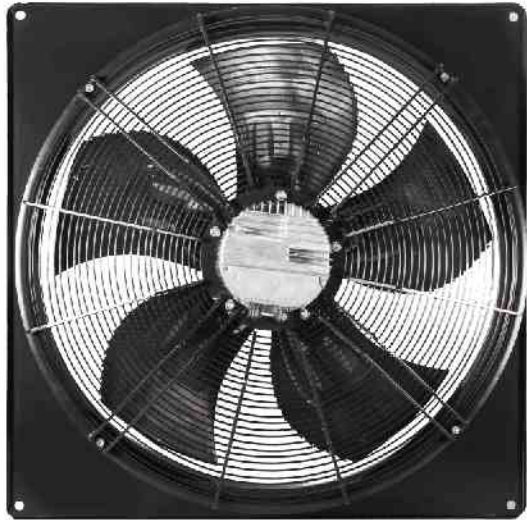

MaEr Fan Motor

Professional · Honest · Human Oriented



型号	电压	频率	功率	风量	电流	转速	噪音
MODEL	Voltage	Frequency	Power	Airflow	Current	RPM	Noise
	V	Hz	W	m³/h	A	r/min	dB(A)
PMSWF112L75-810H-710	3~400	50/60	750	14500	1.4	960	76

注：性能曲线在安装马尔导风圈时测得。 Note: The performance curve is tested with MaEr wall plate.

Material:	Impeller: ABS; Rotor: Coated in black; Electronics enclosure: Die-cast aluminum
Fan blade:	5-pack
Direction of rotation:	Counter clockwise, view from end cover
Type of protection:	IP54
Mounting position:	Horizontal or Vertical
Operation Mode:	S1
Bearings:	Maintenance-free ball bearings
Technical features:	Control input: 0~10V DC/PWM; Current input control: 4-20mA; 20v DC±10%, max. 50mA Integrated PID controller; Speed signal feedback; relay Dual auxiliary output power supplies: 10V DC±10%, max.10mA
Protection:	Current limitation, Stall protection, Soft start protection, Open phase protection, Overheating protection, Over/ Under voltage protection
EMC:	According to EN61000-6-3/2, EN61000-3-2/3
Approvals:	CCC, CE
Amb.Temp:	-40~+65 °C
Insulation class:	F
材料:	风轮-ABS; 转子-镀黑; 电气罩-压铸铝
叶片数:	5
电机防护等级:	逆时针
从引出线端看为:	IP54
安装位置:	竖直、水平线2个方向
连续工作制:	(S1)
轴承:	免维护轴承
电气特性:	控制信号输入: 0~10V DC/PWM; 电流控制: 4-20mA; 集成PID调节; 速度反馈信号; 报警信号继电器 双路辅助电源: 10V DC±10%, max.10mA; 20v DC±10%, max.50mA
保护:	限流、堵转、软启动、缺相故障、过温保护、过/欠压保护
EMC:	符合EN61000-6-3/2, EN61000-3-2/3
证书:	CCC、CE认证
环境温度:	-40~+65°C
绝缘等级:	F

MaEr Fan Motor

Professional · Honest · Human Oriented



MaEr Fan Motor

Professional · Honest · Human Oriented



150-400V SERIES MOTOR WIRING INSTRUCTION 150电机系列接线说明图

Wiring indication 接线标识图

P3											P2			P1				
RSA	RSB	RSA	RSB	GND	Ain1 U	4~20mA	20V	10V	Din1	GND	FG	NO	COM	NC	L3	L2	L1	PE

Portal function 接线端口功能说明图

序号	信号	分配/功能	序号	信号	分配/功能
	L3	交流电接入, 供给电压3~380-480VAC;频率50/60Hz	RSA		RS485总线连接; RSA;MODBUS通讯协议RTU方式
P1	L2	交流电接入, 供给电压3~380-480VAC;频率50/60Hz	RSB		RS485总线连接; RSB;MODBUS通讯协议RTU方式
	L1	交流电接入, 供给电压3~380-480VAC;频率50/60Hz	GND		接口P3控制信号地
PE	PE	接地线, PE连接	Ain1 U		控制输入0~10VDC/PWM
	NO	状态继电器, 浮动状态触点; 常开; 关闭错误	4~20mA		控制输入 4~20mA
P2	COM	状态继电器, 公共连接; 连接等级250VAC/2A	P3	20V	固定电压输出20VDC (±10%最大.50mA)
	NC	状态继电器, 常闭, 解除错误		10V	固定电压输出10VDC (±10%最大.10mA)
					数字式输入端1电子设备的接通
			Din1		接通: 管脚为开路或者所施加的电压为5到50VDC; 截止: 接地桥接或者所施加的电压<1VDC.
			FG		速度反馈信号

HUB	Portal	Description/Function	HUB	Portal	Description/Function
	L3	AC power in, voltage input 3~380-480V;50/60Hz	RSA		Bus RS485; RSA; MODBUS RTU
P1	L2	AC power in, voltage input 3~380-480V;50/60Hz	RSB		Bus RS485; RSB; MODBUS RTU
	L1	AC power in, voltage input 3~380-480V;50/60Hz	GND		Interface P3 for signal control, ground
PE	PE	Protect earthing, ground	Ain1 U		Analogue input 1(set value) 0~10V DC/PWM
	NO	Status relay, alterable state contact; normally turn-on; turn-off when error	4~20mA		Analogue Control input 4~20mA
P2	COM	State relay, universal connectivity; contact rating 250V AC/2A	P3	20V	Rated voltage output 20VDC (±10% max. 50mA)
	NC	State relay, normally turn-off ,turn-on when error		10V	Rated voltage output 10VDC (±10% max. 10mA)
					Connection of Digital input 1 enabling of electronics
			Din1		enabling: oping pin or applied voltage 5-50V DC; disabling: bridge to GND or applied voltage<1V DC
			FG		Speed Signal Feedback(Fault Feedback)

EC AXIAL FAN
EC外转子轴流风机

3-400V EC150电机

MaEr Fan Motor

Professional · Honest · Human Oriented



Ø 710 EC AXIAL FAN EC 外转子轴流风机

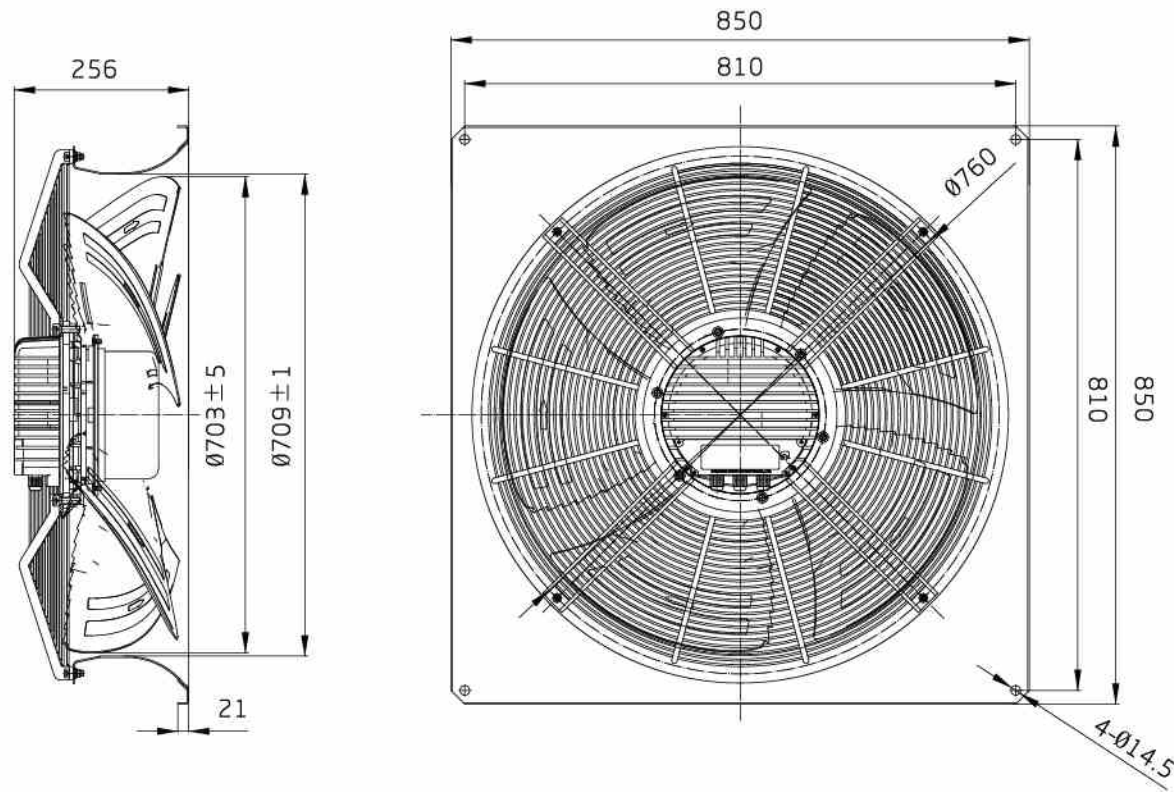
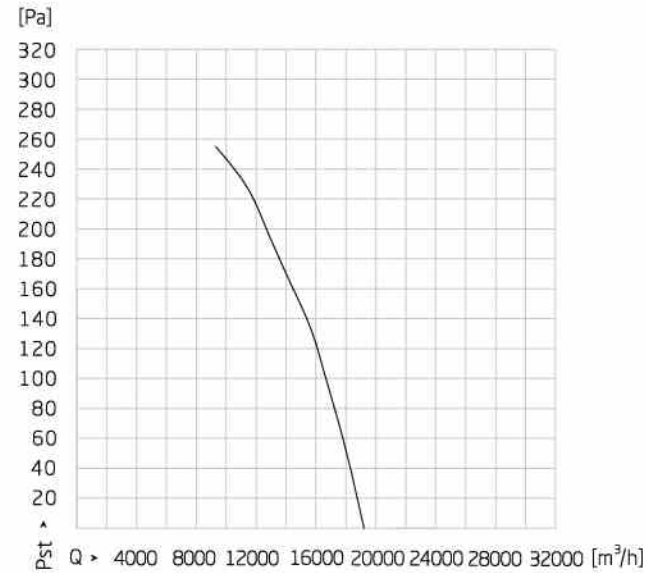
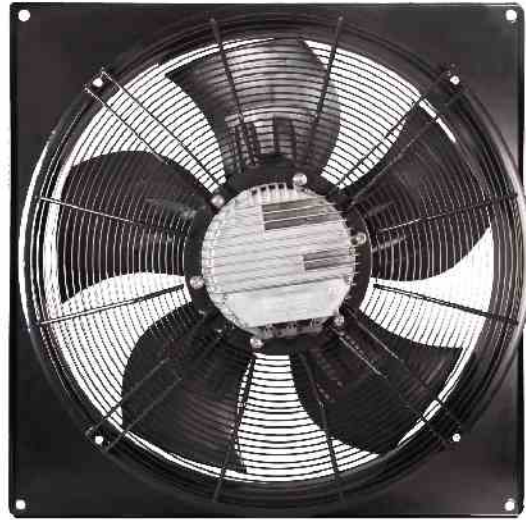

MaEr Fan Motor

Professional · Honest · Human Oriented



型号	电压	频率	功率	风量	电流	转速	噪音
MODEL	Voltage	Frequency	Power	Airflow	Current	RPM	Noise
	V	Hz	W	m³/h	A	r/min	dB(A)
PMSWF150L50-810H-710	3~400	50/60	1396	19249	2.37	1200	81

注：性能曲线在安装马尔导风圈时测得。 Note: The performance curve is tested with MaEr wall plate.

Material:	Impeller: ABS; Rotor: Coated in black; Electronics enclosure: Die-cast aluminum
Fan blade:	5-pack
Direction of rotation:	Counter clockwise, view from end cover
Type of protection:	IP54
Mounting position:	Horizontal or Vertical
Operation Mode:	S1
Bearings:	Maintenance-free ball bearings
Technical features:	Control input: 0~10V DC/PWM; Current input control: 4-20mA; 20v DC±10%, max. 50mA Integrated PID controller; Speed signal feedback; relay Dual auxiliary output power supplies: 10V DC±10%, max.10mA
Protection:	Current limitation, Stall protection, Soft start protection, Open phase protection, Overheating protection, Over/ Under voltage protection
EMC:	According to EN61000-6-3/2, EN61000-3-2/3
Approvals:	CCC, CE
Amb.Temp:	-40~+65℃
Insulation class:	F
材料:	风轮-ABS; 转子-镀黑; 电气罩-压铸铝
叶片数:	5
电机防护等级:	逆时针
从引出线端看为:	IP54
安装位置:	竖直、水平线2个方向
连续工作制:	(S1)
轴承:	免维护轴承
电气特性:	控制信号输入: 0~10V DC/PWM; 电流控制: 4-20mA; 集成PID调节; 速度反馈信号; 报警信号继电器 双路辅助电源: 10V DC±10%, max.10mA; 20v DC±10%, max.50mA
保护:	限流、堵转、软启动、缺相故障、过温保护、过/欠压保护
EMC:	符合EN61000-6-3/2, EN61000-3-2/3
证书:	CCC、CE认证
环境温度:	-40~+65℃
绝缘等级:	F

MaEr Fan Motor

Professional · Honest · Human Oriented



Ø 800 EC AXIAL FAN EC 外转子轴流风机

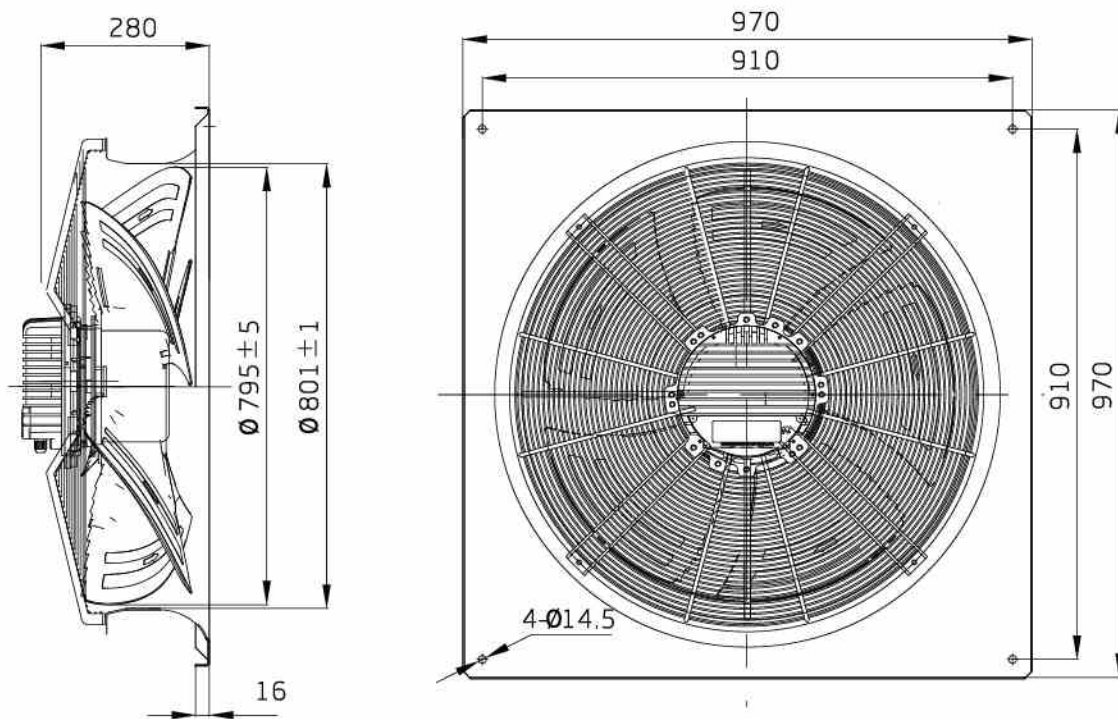
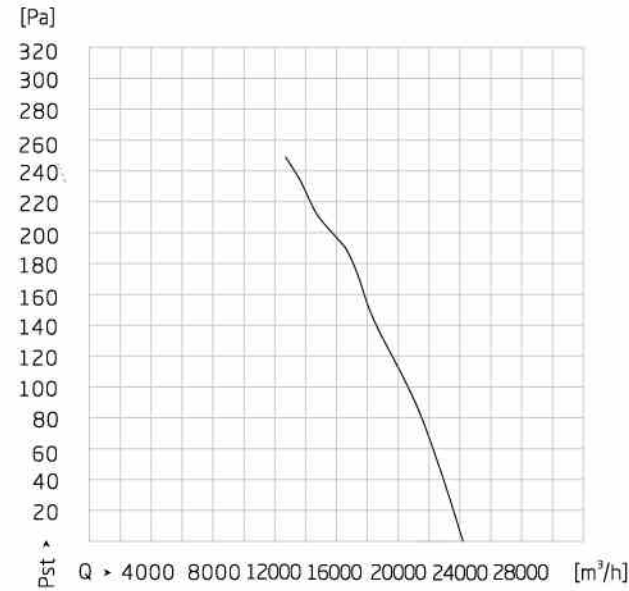

MaEr Fan Motor

Professional · Honest · Human Oriented



型号	电压	频率	功率	风量	电流	转速	噪音
MODEL	Voltage	Frequency	Power	Airflow	Current	RPM	Noise
	V	Hz	W	m³/h	A	r/min	dB(A)
PMSWF150L85-910H-800	3~400	50/60	1580	24220	2.57	1000	78

注：性能曲线在安装马尔导风圈时测得。 Note: The performance curve is tested with MaEr wall plate.

Material:	Impeller: ABS; Rotor: Coated in black; Electronics enclosure: Die-cast aluminum
Fan blade:	5-pack
Direction of rotation:	Counter clockwise, view from end cover
Type of protection:	IP54
Mounting position:	Horizontal or Vertical
Operation Mode:	S1
Bearings:	Maintenance-free ball bearings
Technical features:	Control input: 0~10V DC/PWM; Current input control: 4-20mA; 20v DC±10%, max. 50mA Integrated PID controller; Speed signal feedback; relay Dual auxiliary output power supplies: 10V DC±10%, max.10mA
Protection:	Current limitation, Stall protection, Soft start protection, Open phase protection, Overheating protection, Over/ Under voltage protection
EMC:	According to EN61000-6-3/2, EN61000-3-2/3
Approvals:	CCC, CE
Amb.Temp:	-40~+65℃
Insulation class:	F
材料:	风轮-ABS; 转子-镀黑; 电气罩-压铸铝
叶片数:	5
电机防护等级:	逆时针
从引出线端看为:	IP54
安装位置:	竖直、水平线2个方向
连续工作制:	(S1)
轴承:	免维护轴承
电气特性:	控制信号输入: 0~10V DC/PWM; 电流控制: 4-20mA; 集成PID调节; 速度反馈信号; 报警信号继电器 双路辅助电源: 10V DC±10%, max.10mA; 20v DC±10%, max.50mA
保护:	限流、堵转、软启动、缺相故障、过温保护、过/欠压保护
EMC:	符合EN61000-6-3/2, EN61000-3-2/3
证书:	CCC、CE认证
环境温度:	-40~+65℃
绝缘等级:	F

MaEr Fan Motor

Professional · Honest · Human Oriented



Ø 900 EC AXIAL FAN EC 外转子轴流风机

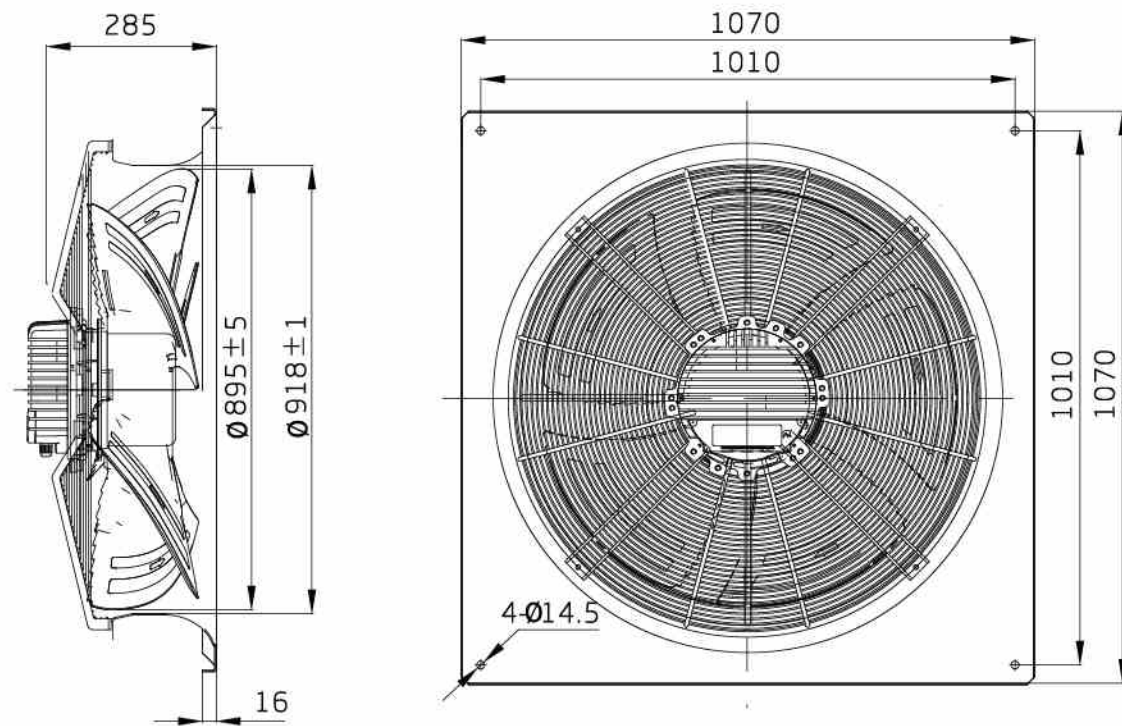
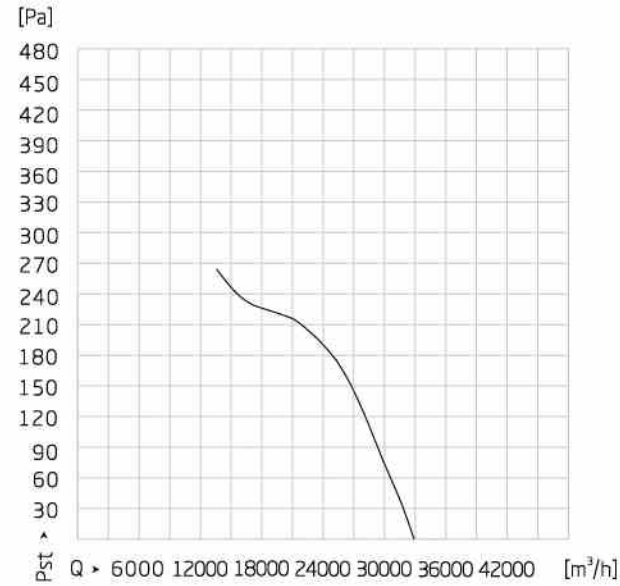

MaEr Fan Motor

Professional · Honest · Human Oriented



型号	电压	频率	功率	风量	电流	转速	噪音
MODEL	Voltage	Frequency	Power	Airflow	Current	RPM	Noise
	V	Hz	W	m³/h	A	r/min	dB(A)
PMSWF150L85-1010H-900	3~400	50/60	1912	32903	3.21	1000	82

注：性能曲线在安装马尔导风扇时测得。 Note: The performance curve is tested with MaEr wall plate.

Material:	Impeller: ABS; Rotor: Coated in black; Electronics enclosure: Die-cast aluminum
Fan blade:	5-pack
Direction of rotation:	Counter clockwise, view from end cover
Type of protection:	IP54
Mounting position:	Horizontal or Vertical
Operation Mode:	S1
Bearings:	Maintenance-free ball bearings
Technical features:	Control input: 0~10V DC/PWM; Current input control: 4-20mA; 20v DC±10%, max. 50mA Integrated PID controller; Speed signal feedback; relay Dual auxiliary output power supplies: 10V DC±10%, max.10mA
Protection:	Current limitation, Stall protection, Soft start protection, Open phase protection, Overheating protection, Over/ Under voltage protection
EMC:	According to EN61000-6-3/2, EN61000-3-2/3
Approvals:	CCC, CE
Amb.Temp:	-40~+65 °C
Insulation class:	F
材料:	风轮-ABS; 转子-镀黑; 电气罩-压铸铝
叶片数:	5
电机防护等级:	逆时针
从引出线端看为:	IP54
安装位置:	竖直、水平线2个方向
连续工作制:	(S1)
轴承:	免维护轴承
电气特性:	控制信号输入: 0~10V DC/PWM; 电流控制: 4-20mA; 集成PID调节; 速度反馈信号; 报警信号继电器 双路辅助电源: 10V DC±10%, max.10mA; 20v DC±10%, max.50mA
保护:	限流、堵转、软启动、缺相故障、过温保护、过/欠压保护
EMC:	符合EN61000-6-3/2, EN61000-3-2/3
证书:	CCC、CE认证
环境温度:	-40~+65°C
绝缘等级:	F



EC BACKWARD CENTRIFUGAL FAN
EC外转子后倾离心风机系列
1-230V EC074电机

074-230V SERIES MOTOR WIRING INSTRUCTION

074电机系列接线说明图

Wiring indication 接线标识图

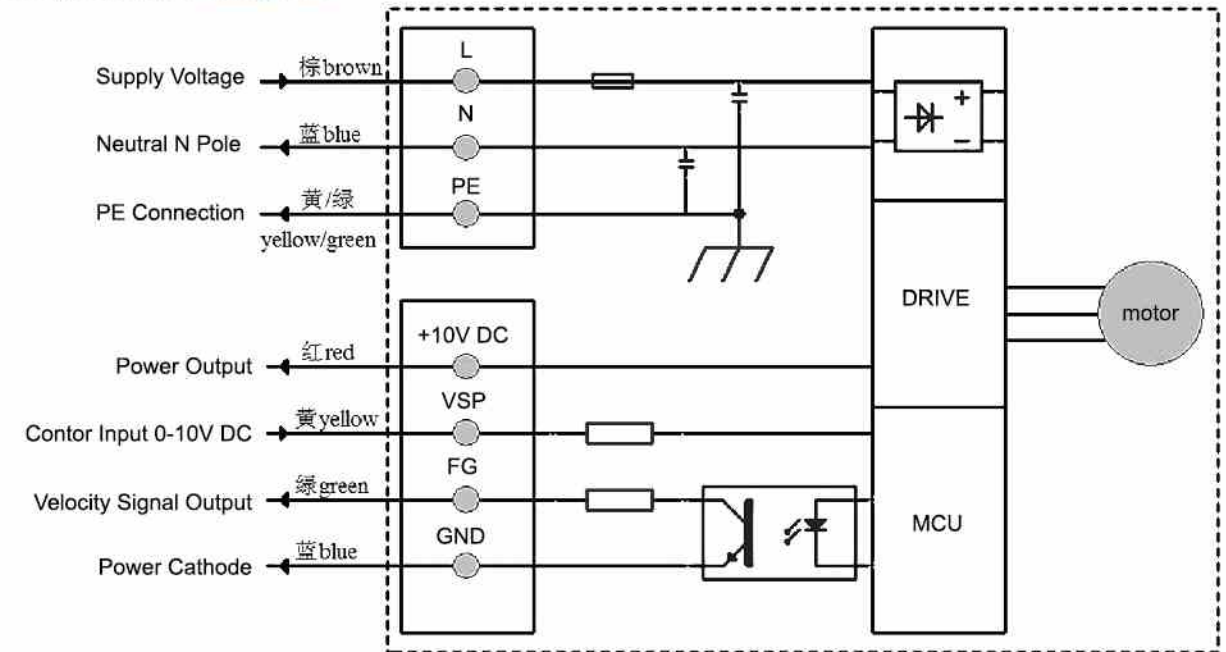

Portal function 接线端口功能说明图

序号	信号	分配/功能	序号	信号	分配/功能
P1	L	交流电接入, 供给电压1~207-277VAC; 频率50/60Hz	P2	GND	接口P2控制信号地
	N	交流电接入, 中性线N极		0~10V/PWM	控制输入0~10VDC/PWM
	PE	接地线, PE连接		FG	速度反馈信号
				10V	固定电压输出10VDC (±10%最大.10mA)

HUB	Portal	Description/Function	HUB	Portal	Description/Function
P1	L	AC power in, Voltage input 1~207-277V; 50/60Hz	P2	GND	Interface P3 for signal control, ground
	N	AC power in, Neutral N pole		0~10V/PWM	Controller input 0~10V DC/PWM
	PE	Protect earthing, ground		FG	Speed Signal Feedback
				10V	Rated voltage output 10V DC (±10% max. 10mA)

MaEr Fan Motor

Professional · Honest · Human Oriented



MaEr Fan Motor

Professional · Honest · Human Oriented



Ø 190 EC BACKWARD CENTRIFUGAL FAN EC 外转子后倾离心风机

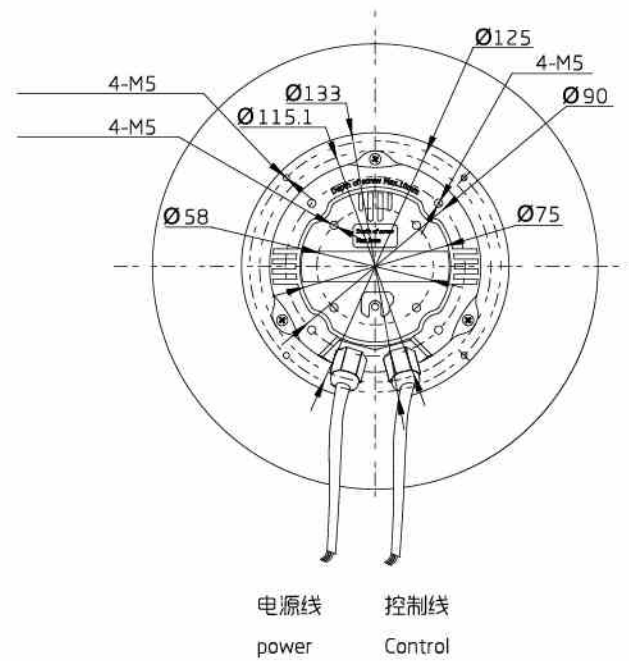
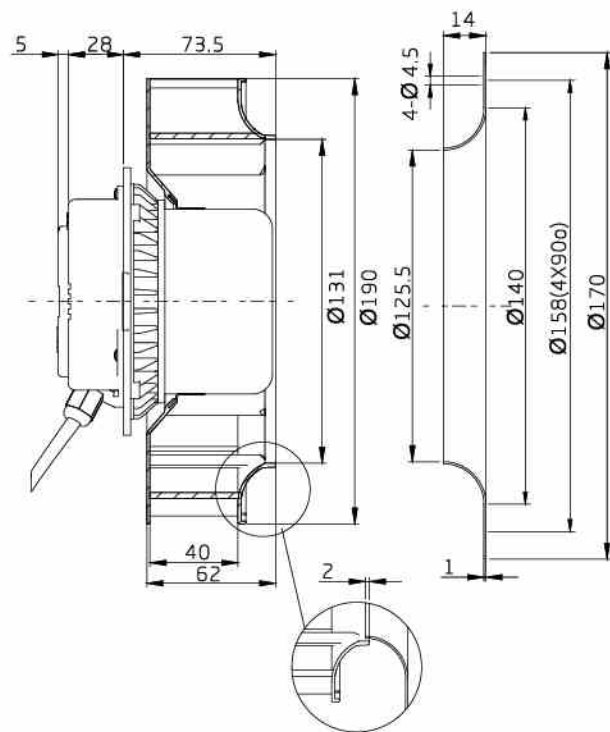
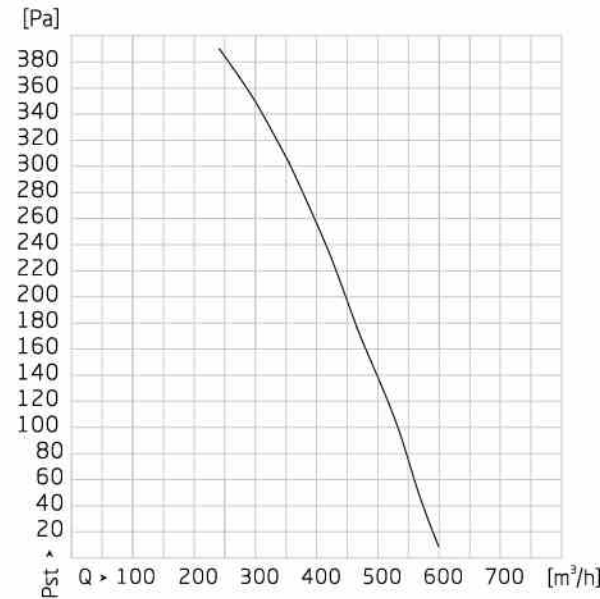

型号	电压	频率	输入功率	转速	电流	静压	环境温度	静压效率	能效值	噪声	备注
Model	Voltage	Frequency	Power	RPM	Current	Psf	Temp.	nsf	EFF.Grade	Noise	Note
	V	Hz	W	r/min	A	Pa	°C	%	N	dB/(A)	
PMDWF74L25-190x62	1~230±10%	50/60	85	3096	0.2	311	-40~+60	35.85	58	68	

Material:	Blade: PP+40%GF; Rotor: Coated in black; Electronics enclosure: Die-cast aluminum
Direction of rotation:	Counter clockwise, view from end cover
Type of protection:	IP54
Mounting position:	Horizontal or Vertical
Operation Mode:	S1
Bearings:	Maintenance-free ball bearings
Technical features:	Control input 0~10V DC/PWM; Integrated PID controller; Speed signal feedback Single auxiliary output power supply: 10V DC±10%, max. 10mA
Protection:	Current limitation, Stall protection, Soft start protection, Open phase protection, Overheating protection, Over/ Under voltage protection
EMC:	According to EN61000-6-3/2, EN61000-3-2/3
Approvals:	CCC, CE
Amb.Temp:	-25~+60°C
Insulation class:	F
材料:	风轮-PP+40%GF; 转子-镀黑; 电气罩-压铸铝
从引出线端看为:	逆时针
电机防护等级:	IP54
安装位置:	竖直、水平线2个方向
连续工作制:	(S1)
轴承:	免维护轴承
电气特性:	控制信号输入: 0~10V DC/PWM; 集成PID调节; 速度反馈信号 单路辅助电源: 10V DC±10%, max.10mA
保护:	限流、堵转、软启动、缺相故障、过温保护、过/欠压保护
EMC:	符合EN61000-6-3/2, EN61000-3-2/3
证书:	CCC、CE认证
环境温度:	-25~+60°C
绝缘等级:	F

Ø 220 EC BACKWARD CENTRIFUGAL FAN EC 外转子后倾离心风机

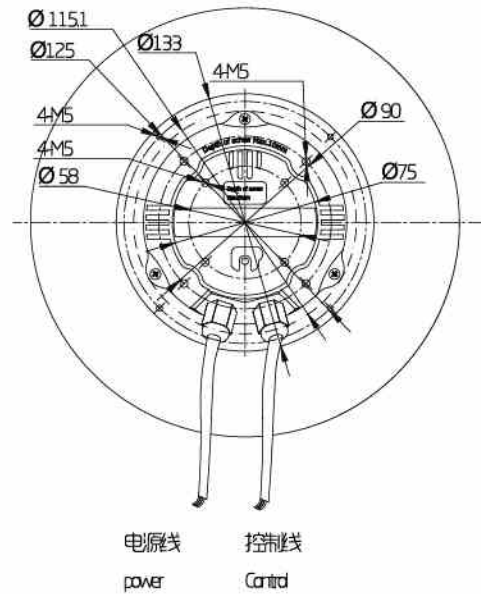
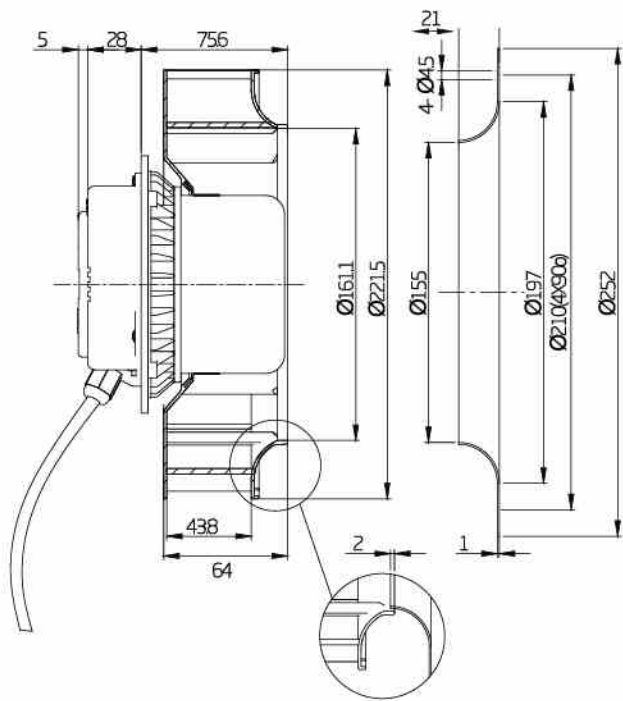
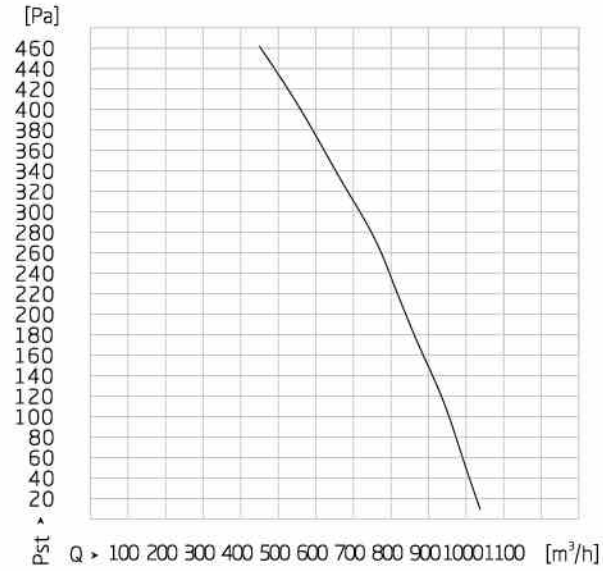

型号	电压	频率	输入功率	转速	电流	静压	环境温度	静压效率	能效值	噪声	备注
Model	Voltage	Frequency	Power	RPM	Current	Psf	Temp.	ηsf	EFF.Grade	Noise	Note
	V	Hz	W	r/min	A	Pa	°C	%	N	dB(A)	
PMDWF74L25-220x64	1~230±10%	50/60	150	3096	1.02	470	-40~+60	42.55	62	71	

Material: Blade: PP+40%GF; Rotor: Coated in black; Electronics enclosure: Die-cast aluminum

Direction of rotation: Counter clockwise, view from end cover

Type of protection: IP54

Mounting position: Horizontal or Vertical

Operation Mode: S1

Bearings: Maintenance-free ball bearings

Technical features: Control input 0~10V DC/PWM; Integrated PID controller; Speed signal feedback

Single auxiliary output power supply: 10V DC±10%, max. 10mA

Protection: Current limitation, Stall protection, Soft start protection, Open phase protection, Overheating protection, Over/ Under voltage protection

EMC: According to EN61000-6-3/2, EN61000-3-2/3

Approvals: CCC, CE

Amb.Temp: -25~+60°C

Insulation class: F

材料: 风轮-PP+40%GF; 转子-镀黑; 电气罩-压铸铝

从引出线端看为: 逆时针

电机防护等级: IP54

安装位置: 竖直、水平线2个方向

连续工作制: (S1)

轴承: 免维护轴承

电气特性: 控制信号输入: 0~10V DC/PWM; 集成PID调节; 速度反馈信号

单路辅助电源: 10V DC±10%, max.10mA

保护: 限流、堵转、软启动、缺相故障、过温保护、过/欠压保护

EMC: 符合EN61000-6-3/2, EN61000-3-2/3

证书: CCC、CE认证

环境温度: -25~+60°C

绝缘等级: F

Ø 225 EC BACKWARD CENTRIFUGAL FAN EC 外转子后倾离心风机

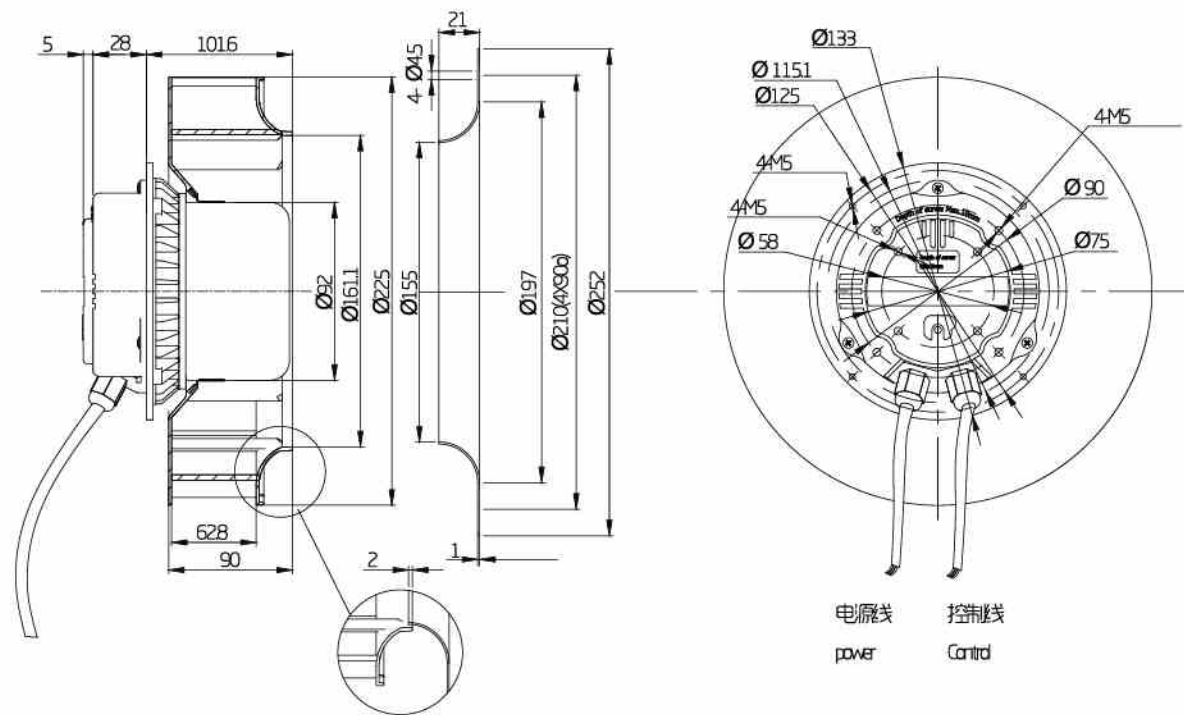
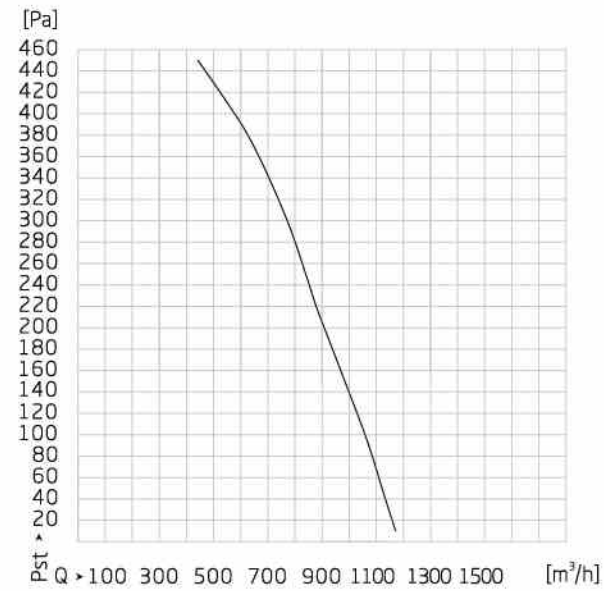

型号	电压	频率	输入功率	转速	电流	静压	环境温度	静压效率	能效值	噪声	备注
Model	Voltage	Frequency	Power	RPM	Current	Psf	Temp.	ηsf	EFF.Grade	Noise	Note
	V	Hz	W	r/min	A	Pa	°C	%	N	dB/(A)	
PMDWF74L25-225x90	1~230±10%	50/60	156	2893	1.06	388	-40~+60	42.6	62	70	

Material:	Blade: PP+40%GF; Rotor: Coated in black; Electronics enclosure: Die-cast aluminum
Direction of rotation:	Counter clockwise, view from end cover
Type of protection:	IP54
Mounting position:	Horizontal or Vertical
Operation Mode:	S1
Bearings:	Maintenance-free ball bearings
Technical features:	Control input 0~10V DC/PWM; Integrated PID controller; Speed signal feedback Single auxiliary output power supply: 10V DC±10%, max. 10mA
Protection:	Current limitation, Stall protection, Soft start protection, Open phase protection, Overheating protection, Over/ Under voltage protection
EMC:	According to EN61000-6-3/2, EN61000-3-2/3
Approvals:	CCC, CE
Amb.Temp:	-25~+60°C
Insulation class:	F
材料:	风轮-PP+40%GF; 转子-镀黑; 电气罩-压铸铝
从引出线端看为:	逆时针
电机防护等级:	IP54
安装位置:	竖直、水平线2个方向
连续工作制:	(S1)
轴承:	免维护轴承
电气特性:	控制信号输入: 0~10V DC/PWM; 集成PID调节; 速度反馈信号 单路辅助电源: 10V DC±10%, max.10mA
保护:	限流、堵转、软启动、缺相故障、过温保护、过/欠压保护
EMC:	符合EN61000-6-3/2, EN61000-3-2/3
证书:	CCC、CE认证
环境温度:	-25~+60°C
绝缘等级:	F

MaEr Fan Motor

Professional · Honest · Human Oriented



MaEr Fan Motor

Professional · Honest · Human Oriented



Ø 250 EC BACKWARD CENTRIFUGAL FAN EC 外转子后倾离心风机

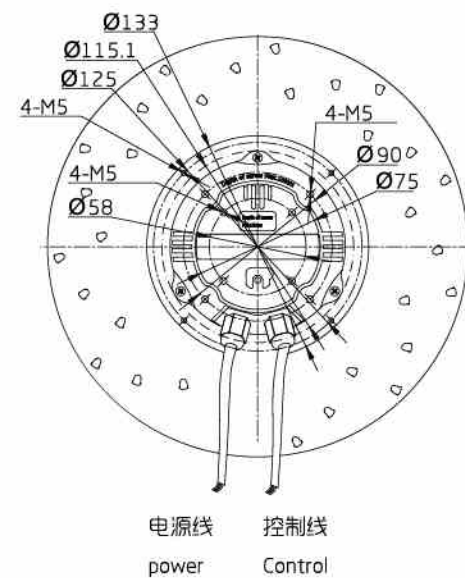
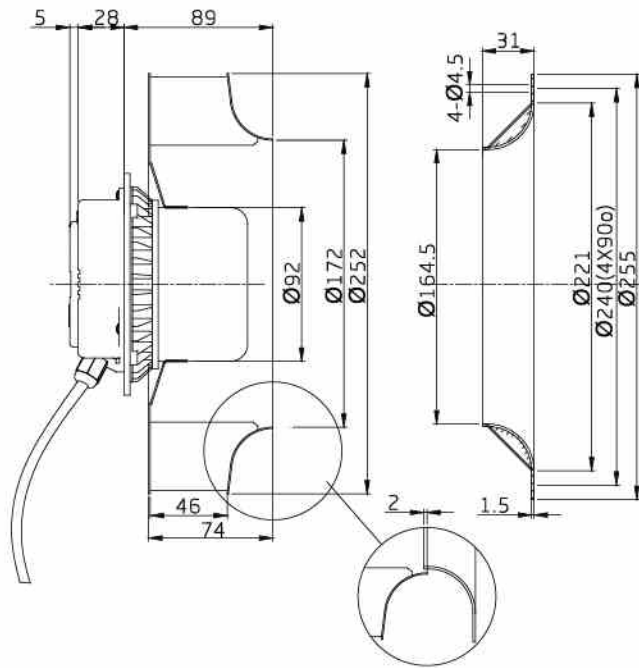
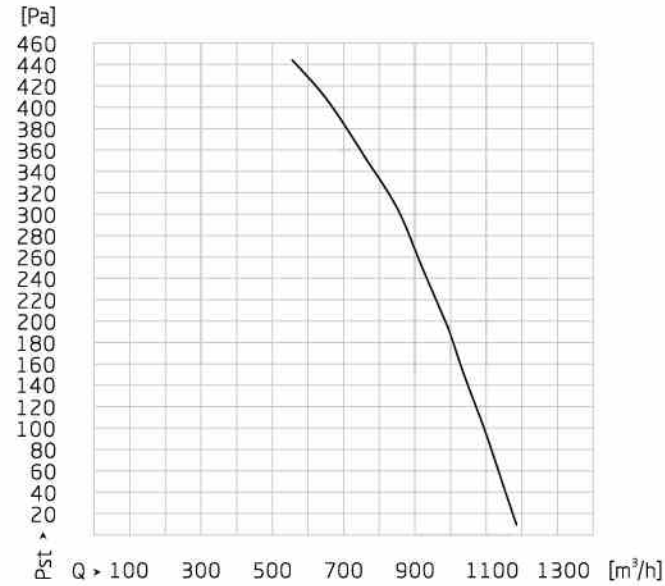

型号	电压	频率	输入功率	转速	电流	静压	环境温度	静压效率	能效值	噪声	备注
Model	Voltage	Frequency	Power	RPM	Current	Psf	Temp.	ηsf	EFF.Grade	Noise	Note
	V	Hz	W	r/min	A	Pa	°C	%	N	dB(A)	
PMDWF74L25-250x75	1~230±10%	50/60	178	2893	1.2	358	-40~+60	42.01	61	71	

Material:	Blade: PP+40%GF; Rotor: Coated in black; Electronics enclosure: Die-cast aluminum
Direction of rotation:	Counter clockwise, view from end cover
Type of protection:	IP54
Mounting position:	Horizontal or Vertical
Operation Mode:	S1
Bearings:	Maintenance-free ball bearings
Technical features:	Control input 0~10V DC/PWM; Integrated PID controller; Speed signal feedback Single auxiliary output power supply: 10V DC±10%, max. 10mA
Protection:	Current limitation, Stall protection, Soft start protection, Open phase protection, Overheating protection, Over/ Under voltage protection
EMC:	According to EN61000-6-3/2, EN61000-3-2/3
Approvals:	CCC, CE
Amb.Temp:	-25~+60°C
Insulation class:	F
材料:	风轮-PP+40%GF; 转子-镀黑; 电气罩-压铸铝
从引出线端看为:	逆时针
电机防护等级:	IP54
安装位置:	竖直、水平线2个方向
连续工作制:	(S1)
轴承:	免维护轴承
电气特性:	控制信号输入: 0~10V DC/PWM; 集成PID调节; 速度反馈信号 单路辅助电源: 10V DC±10%, max.10mA
保护:	限流、堵转、软启动、缺相故障、过温保护、过/欠压保护
EMC:	符合EN61000-6-3/2, EN61000-3-2/3
证书:	CCC、CE认证
环境温度:	-25~+60°C
绝缘等级:	F

MaEr Fan Motor

Professional · Honest · Human Oriented



MaEr Fan Motor

Professional · Honest · Human Oriented



Ø 250 EC BACKWARD CENTRIFUGAL FAN EC 外转子后倾离心风机

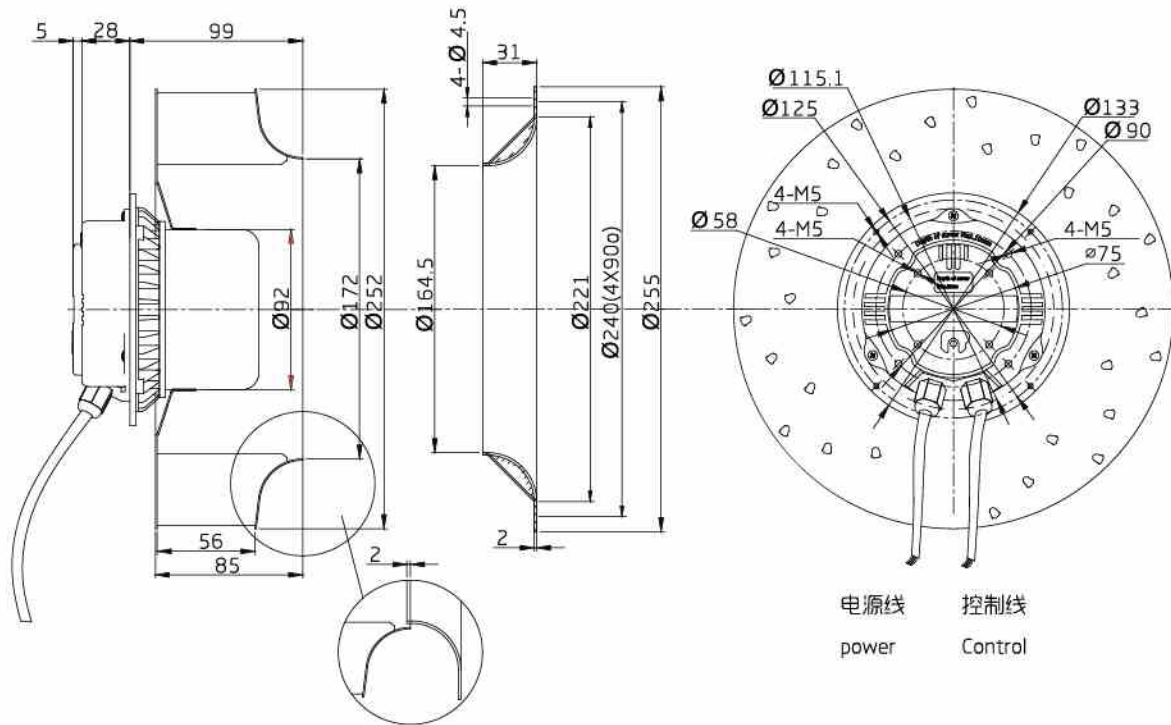
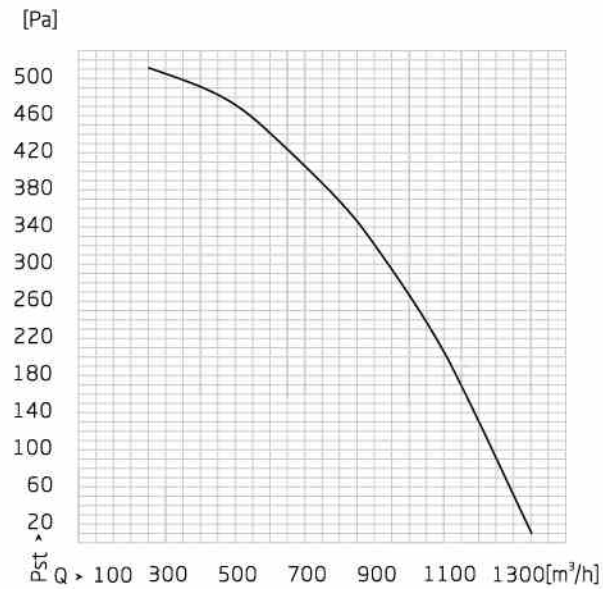

型号	电压	频率	输入功率	转速	电流	静压	环境温度	静压效率	能效值	噪声	备注
Model	Voltage	Frequency	Power	RPM	Current	Psf	Temp.	ηsf	EFF.Grade	Noise	Note
	V	Hz	W	r/min	A	Pa	°C	%	N	dB(A)	
PMDWF74L25-250x85	1~230±10%	50/60	192	2703	1.3	301	-40~+60	41.01	59	71	

Material:	Blade: PP+40%GF; Rotor: Coated in black; Electronics enclosure: Die-cast aluminum
Direction of rotation:	Counter clockwise, view from end cover
Type of protection:	IP54
Mounting position:	Horizontal or Vertical
Operation Mode:	S1
Bearings:	Maintenance-free ball bearings
Technical features:	Control input 0~10V DC/PWM; Integrated PID controller; Speed signal feedback Single auxiliary output power supply: 10V DC±10%, max. 10mA
Protection:	Current limitation, Stall protection, Soft start protection, Open phase protection, Overheating protection, Over/ Under voltage protection
EMC:	According to EN61000-6-3/2, EN61000-3-2/3
Approvals:	CCC, CE
Amb.Temp:	-25~+60°C
Insulation class:	F

材料:	风轮-PP+40%GF; 转子-镀黑; 电气罩-压铸铝
从引出线端看为:	逆时针
电机防护等级:	IP54
安装位置:	竖直、水平2个方向
连续工作制:	(S1)
轴承:	免维护轴承
电气特性:	控制信号输入: 0~10V DC/PWM; 集成PID调节; 速度反馈信号 单路辅助电源: 10V DC±10%, max.10mA
保护:	限流、堵转、软启动、缺相故障、过温保护、过/欠压保护
EMC:	符合EN61000-6-3/2, EN61000-3-2/3
证书:	CCC、CE认证
环境温度:	-25~+60°C
绝缘等级:	F

Ø 280 EC BACKWARD CENTRIFUGAL FAN EC 外转子后倾离心风机

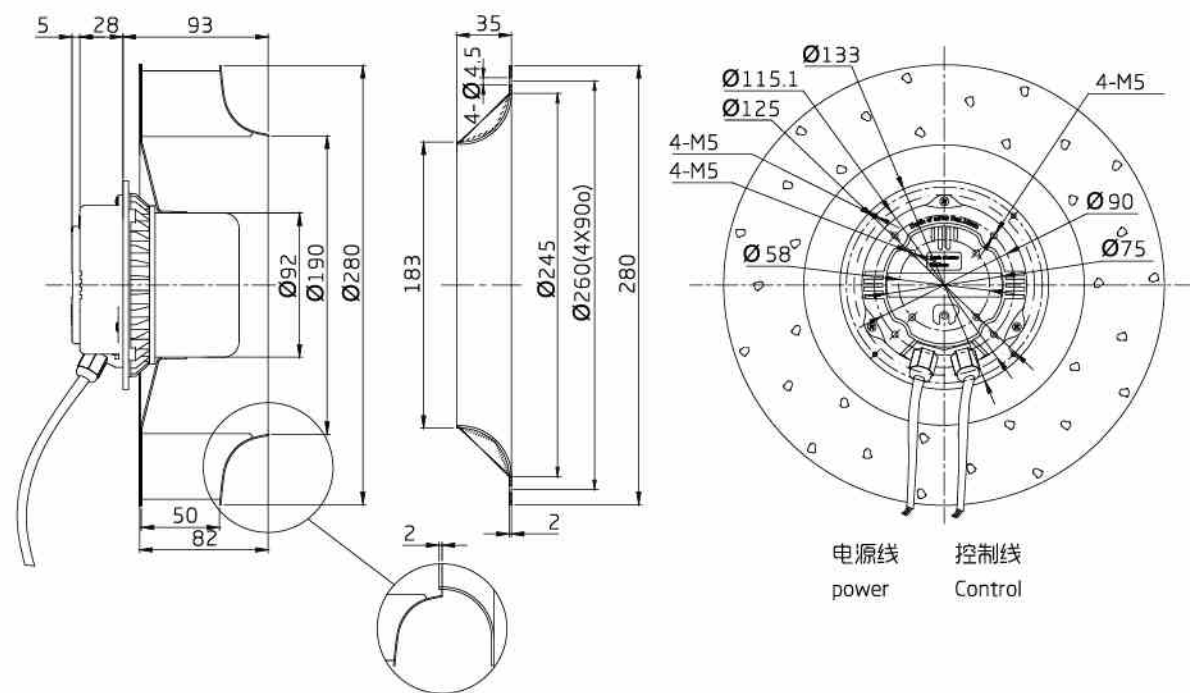
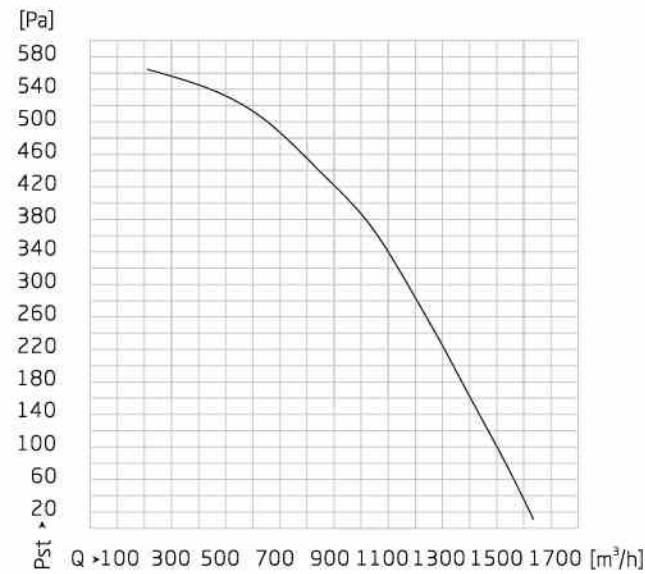

型号	电压	频率	输入功率	转速	电流	静压	环境温度	静压效率	能效值	噪声	备注
Model	Voltage	Frequency	Power	RPM	Current	Psf	Temp.	ηsf	EFF.Grade	Noise	Note
	V	Hz	W	r/min	A	Pa	°C	%	N	dB(A)	
PMDWF74L25-280x82	1~230±10%	50/60	240	2487	1.6	444	-40~+60	44.92	62	78	

Material: Blade: PP+40%GF; Rotor: Coated in black; Electronics enclosure: Die-cast aluminum

Direction of rotation: Counter clockwise, view from end cover

Type of protection: IP54

Mounting position: Horizontal or Vertical

Operation Mode: S1

Bearings: Maintenance-free ball bearings

Technical features: Control input 0~10V DC/PWM; Integrated PID controller; Speed signal feedback

Single auxiliary output power supply: 10V DC±10%, max. 10mA

Protection: Current limitation, Stall protection, Soft start protection, Open phase protection, Overheating protection, Over/ Under voltage protection

EMC: According to EN61000-6-3/2, EN61000-3-2/3

Approvals: CCC, CE

Amb.Temp: -25~+60°C

Insulation class: F

材料: 风轮-PP+40%GF; 转子-镀黑; 电气罩-压铸铝

从引出线端看为: 逆时针

电机防护等级: IP54

安装位置: 竖直、水平2个方向

连续工作制: (S1)

轴承: 免维护轴承

电气特性: 控制信号输入: 0~10V DC/PWM; 集成PID调节; 速度反馈信号

单路辅助电源: 10V DC±10%, max.10mA

保护: 限流、堵转、软启动、缺相故障、过温保护、过/欠压保护

EMC: 符合EN61000-6-3/2, EN61000-3-2/3

证书: CCC、CE认证

环境温度: -25~+60°C

绝缘等级: F



EC BACKWARD CENTRIFUGAL FAN
EC外转子后倾离心风机系列

1-230V EC084电机

084-220V SERIES MOTOR WIRING INSTRUCTION 084电机系列接线说明图

Wiring indication 接线标识图

P1				P2			P3				
GND	0~10V	FG	10V	NO	COM	NC	L		N		PE

Portal function 接线端口功能说明图

序号	信号	分配/功能	序号	信号	分配/功能
PE	PE(黄/绿)	接地线, PE连接	P3	10V(红)	固定电压输出10VDC (+10%最大.10mA)
P1	N (蓝)	交流电接入, 中性线N极		FG(绿)	速度反馈信号
	L(棕)	交流电接入, 供给电压1~207-277VAC;频率50/60Hz		0~10V/PWM(黄)	控制输入0~10VDC/PWM
P2	NO(橙)	状态继电器, 浮动状态触点; 常开; 关闭错误		GND(蓝)	接口P3控制信号地
	COM(灰)	状态继电器, 公共连接; 连接等级250VAC/2A			
	NC(白)	状态继电器, 常闭, 解除错误			

HUB	Portal	Description/Function	HUB	Portal	Description/Function
PE	PE (Yellow/Green)	Earth connection, PE connection	P3	10V (Red)	Rated voltage output 10V DC (±10% max. 10mA)
	P1	N (Blue)		AC power in, Neutral N pole	FG (Green)
L (Brown)		AC power in, 1~207-277V AC; 50/60Hz		0~10V/PWM (Yellow)	Control input 0~10V DC/PWM
P2	NO (Orange)	Status relay, Floating status contact; make for failure		GND (Blue)	Interface P3 for signal control, ground
	COM (Gray)	Status relay, common connection; contact reating 250V AC/2A			
	NC (White)	Status relay, normally closed, break for failure			

Ø 315 EC BACKWARD CENTRIFUGAL FAN EC 外转子后倾离心风机

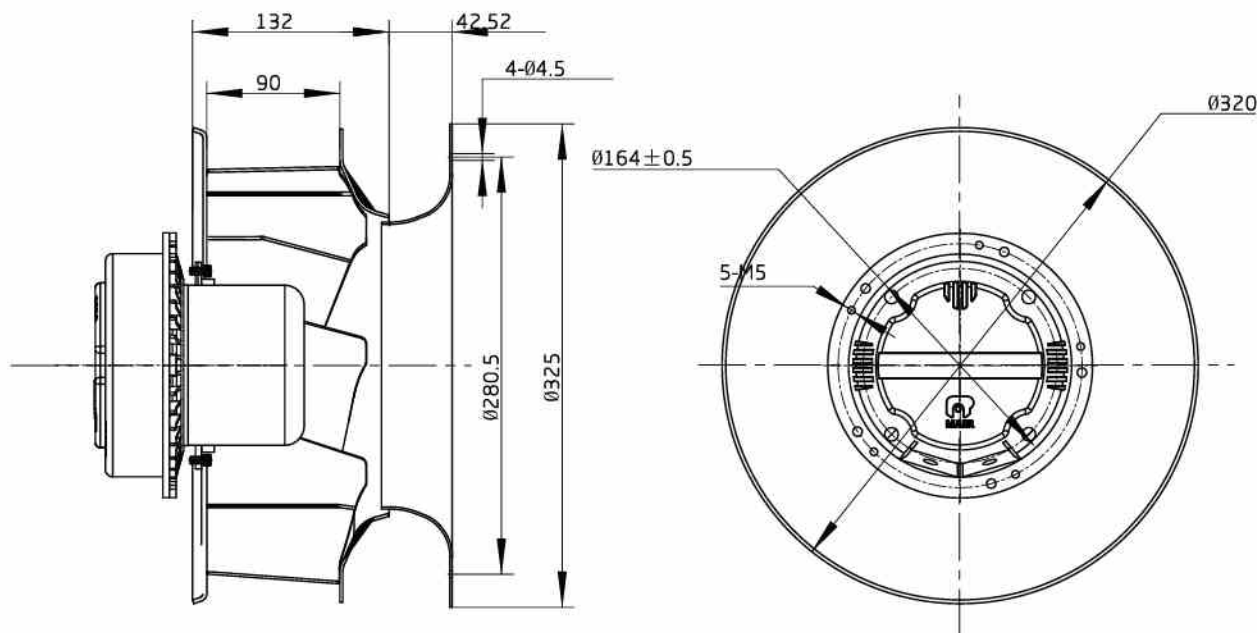
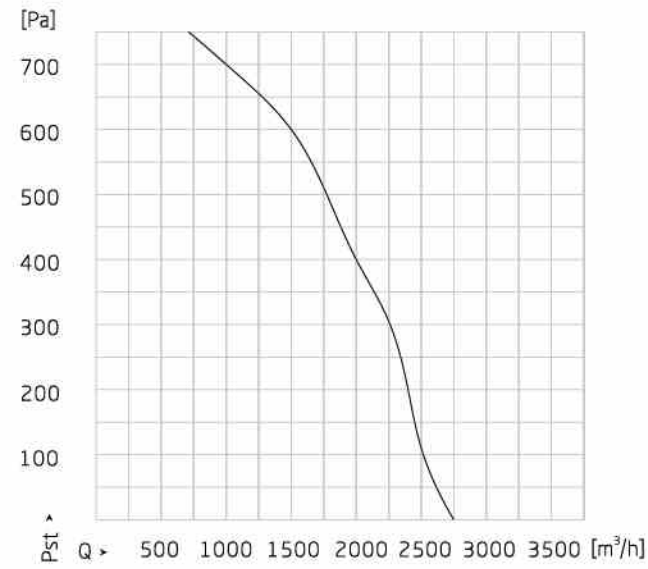

型号	电压	频率	功率	风量	电流	转速	噪音
MODEL	Voltage	Frequency	Power	Airflow	Current	RPM	Noise
	V	Hz	W	m³/h	A	r/min	dB(A)
PMDWF084L50P10-B315X139	1~230	50/60	360	2650	2.3	2600	70

Material:	Impeller: ABS; Rotor: Coated in black; Electronics enclosure: Die-cast aluminum
Direction of rotation:	Counter clockwise, view from end cover
Type of protection:	IP54
Mounting position:	Horizontal or Vertical
Operation Mode:	S1
Bearings:	Maintenance-free ball bearings
Technical features:	Control input 0~10V DC/PWM; PFC (active); Integrated PID controller; Speed signal feedback ; Relay Single auxiliary output power supply: 10V DC±10%, max.10mA
Protection:	Current limitation, Stall protection, Soft start protection, Open phase protection, Overheating protection, Over/ Under voltage protection
EMC:	According to EN61000-6-3/2, EN61000-3-2/3
Approvals:	CCC, CE
Amb.Temp:	-25~+60°C
Insulation class:	F

材料:	风轮-ABS; 转子-镀黑; 电气罩-压铸铝
从引出线端看为:	逆时针
电机防护等级:	IP54
安装位置:	竖直、水平线2个方向
连续工作制:	(S1)
轴承:	免维护轴承
电气特性:	控制信号输入: 0~10V DC/PWM; 含主动式PFC电路; 集成PID调节; 速度反馈信号; 报警信号继电器 单路辅助电源: 10V DC±10%, max.10mA
保护:	限流、堵转、软启动、缺相故障、过温保护、过/欠压保护
EMC:	符合EN61000-6-3/2, EN61000-3-2/3
证书:	CCC、CE认证
环境温度:	-25~+60°C
绝缘等级:	F

MaEr Fan Motor

Professional · Honest · Human Oriented



MaEr Fan Motor

Professional · Honest · Human Oriented



Ø 355 EC BACKWARD CENTRIFUGAL FAN EC 外转子后倾离心风机

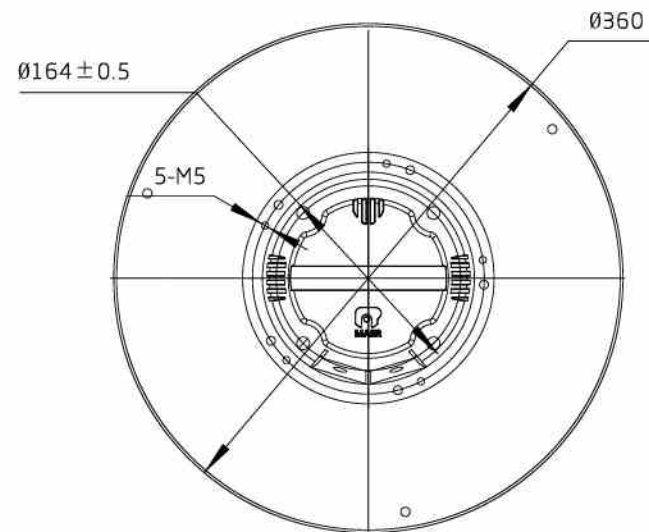
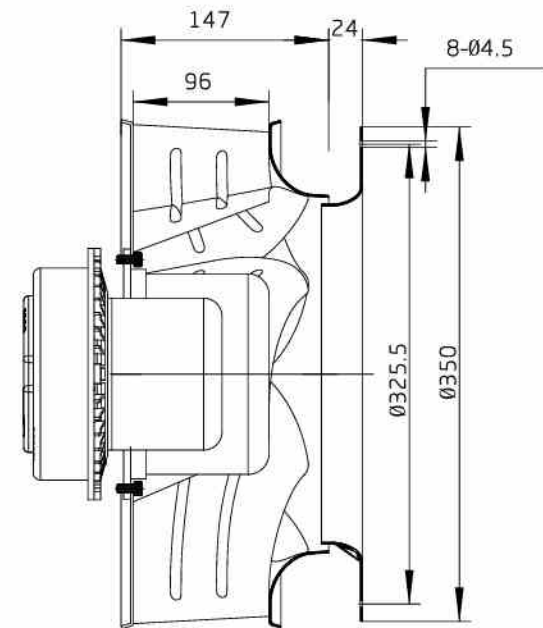
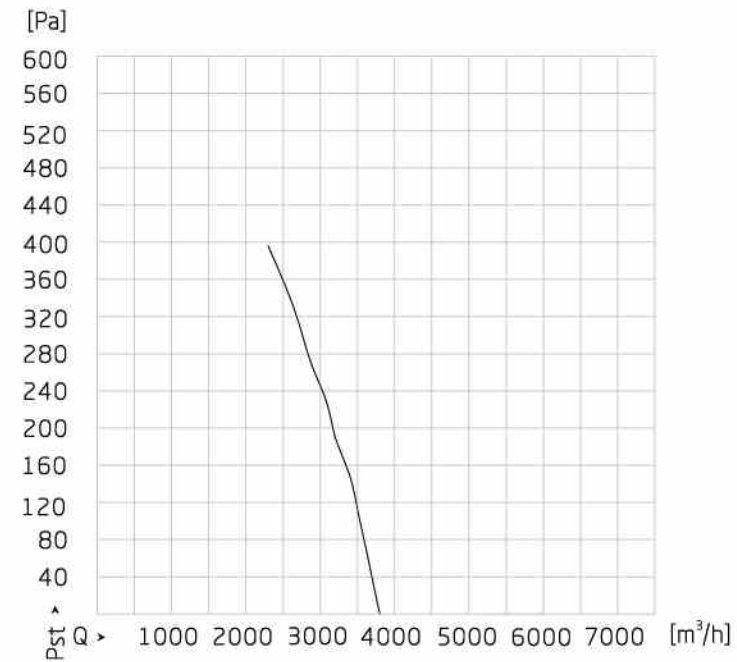

型号	电压	频率	功率	风量	电流	转速	噪音
MODEL	Voltage	Frequency	Power	Airflow	Current	RPM	Noise
	V	Hz	W	m³/h	A	r/min	dB(A)
PMDWF084L50P10-B355X147	1~230	50/60	500	3800	1.50	1900	70

Material:	Impeller: ABS; Rotor: Coated in black; Electronics enclosure: Die-cast aluminum
Direction of rotation:	Counter clockwise, view from end cover
Type of protection:	IP54
Mounting position:	Horizontal or Vertical
Operation Mode:	S1
Bearings:	Maintenance-free ball bearings
Technical features:	Control input 0~10V DC/PWM; PFC (active); Integrated PID controller; Speed signal feedback ; Relay Single auxiliary output power supply: 10V DC±10%, max.10mA
Protection:	Current limitation, Stall protection, Soft start protection, Open phase protection, Overheating protection, Over/ Under voltage protection
EMC:	According to EN61000-6-3/2, EN61000-3-2/3
Approvals:	CCC, CE
Amb.Temp:	-25~+60°C
Insulation class:	F

材料:	风轮-ABS; 转子-镀黑; 电气罩-压铸铝
从引出线端看为:	逆时针
电机防护等级:	IP54
安装位置:	竖直、水平线2个方向
连续工作制:	(S1)
轴承:	免维护轴承
电气特性:	控制信号输入: 0~10V DC/PWM; 含主动式PFC电路; 集成PID调节; 速度反馈信号; 报警信号继电器 单路辅助电源: 10V DC±10%, max.10mA
保护:	限流、堵转、软启动、缺相故障、过温保护、过/欠压保护
EMC:	符合EN61000-6-3/2, EN61000-3-2/3
证书:	CCC、CE认证
环境温度:	-25~+60°C
绝缘等级:	F



EC BACKWARD CENTRIFUGAL FAN
EC外转子后倾离心风机系列

3-400V EC112电机

112-400V SERIES MOTOR WIRING INSTRUCTION 112电机系列接线说明图

Wiring indication 接线标识图

P3								P2			P1			
RSA	RSB	4~20mA	20V	10V	0~10V	GND	FG	NO	COM	NC	L3	L2	L1	PE

Portal function 接线端口功能说明图

序号	信号	分配/功能	序号	信号	分配/功能
	L3	交流电接入, 供给电压3~380-480VAC;频率50/60Hz		RSA	RS485总线连接; RSA;MODBUS通讯协议RTU方式
P1	L2	交流电接入, 供给电压3~380-480VAC;频率50/60Hz		RSB	RS485总线连接; RSB;MODBUS通讯协议RTU方式
	L1	交流电接入, 供给电压3~380-480VAC;频率50/60Hz		GND	接口P3控制信号地
PE	PE	接地线, PE连接	P3	0~10V/PWM	控制输入0~10VDC/PWM
	NO	状态继电器, 浮动状态触点; 常开; 关闭错误		4~20mA	控制输入 4~20mA
P2	COM	状态继电器, 公共连接; 连接等级250VAC/2A		20V	固定电压输出20VDC (±10%最大.50mA)
	NC	状态继电器, 常闭, 解除错误		10V	固定电压输出10VDC (±10%最大.10mA)
				FG	速度反馈信号

HUB	Portal	Description/Function	HUB	Portal	Description/Function
	L3	AC power in, voltage input 3~380-480V; 50/60Hz		RSA	Bus RS485; RSA; MODBUS RTU
P1	L2	AC power in, voltage input 3~380-480V; 50/60Hz		RSB	Bus RS485; RSA; MODBUS RTU
	L1	AC power in, voltage input 3~380-480V; 50/60Hz		GND	Interface P3 for signal control, ground
PE	PE	Protect earthing, ground		0~10V/PWM	Controller input 0~10V DC/PWM
	NO	State relay, alterable state contact; normally turn-on; turn-off when error	P3	4~20mA	Analogue Control input 4~20mA
P2	COM	State relay, universal connectivity; contact rating 250V AC/2A		20V	Rated voltage output 20VDC (±10% max. 50mA)
	NC	State relay, normally turn-off, turn-on when error		10V	Rated voltage output 10VDC (±10% max. 10mA)
				FG	Speed Signal Feedback

MaEr Fan Motor

Professional · Honest · Human Oriented



MaEr Fan Motor

Professional · Honest · Human Oriented



Ø 400 EC BACKWARD CENTRIFUGAL FAN EC 外转子后倾离心风机

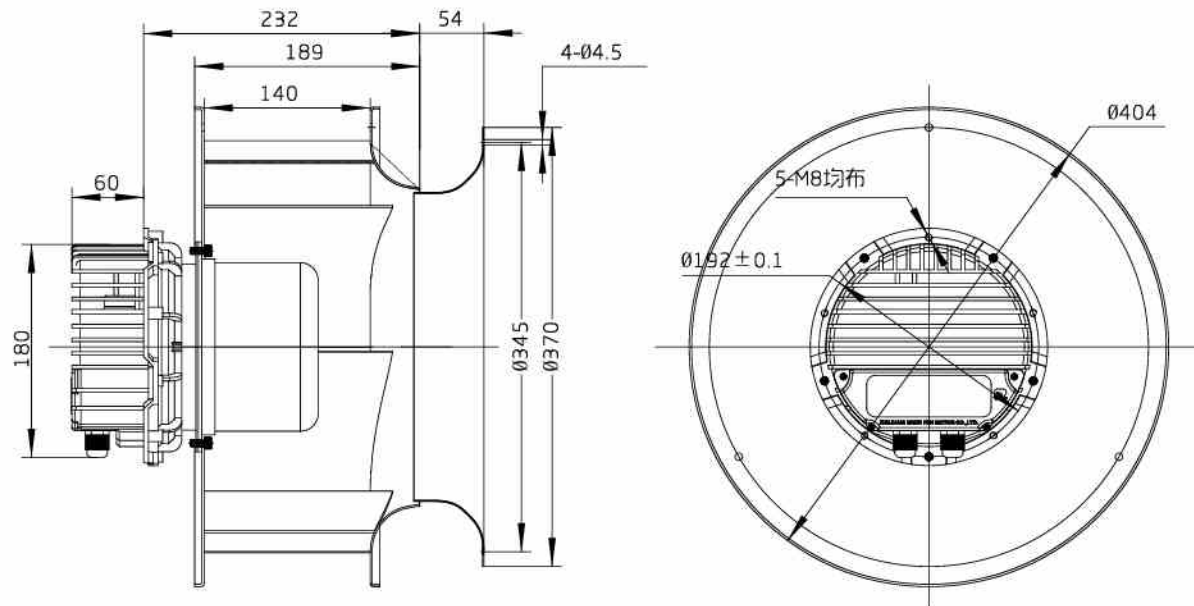
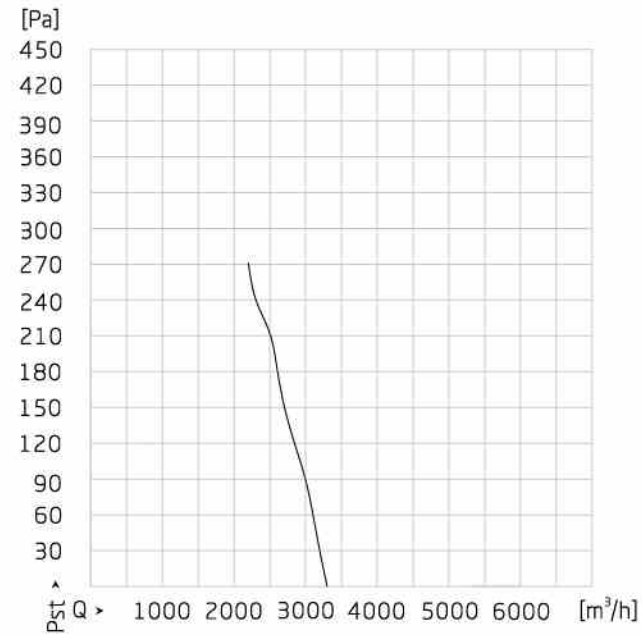

型号	电压	频率	功率	风量	电流	转速	噪音
MODEL	Voltage	Frequency	Power	Airflow	Current	RPM	Noise
	V	Hz	W	m³/h	A	r/min	dB(A)
PMSWF112L60P10-B400X188	3~400	50/60	400	4000	2.0	1500	76

Material:	Impeller: ABS; Rotor: Coated in black; Electronics enclosure: Die-cast aluminum
Direction of rotation:	Counter clockwise, view from end cover
Type of protection:	IP54
Mounting position:	Horizontal or Vertical
Operation Mode:	S1
Bearings:	Maintenance-free ball bearings
Technical features:	Control input 0~10V DC/PWM; PFC (active); Integrated PID controller; Speed signal feedback ; Relay Single auxiliary output power supply: 10V DC±10%, max.10mA
Protection:	Current limitation, Stall protection, Soft start protection, Open phase protection, Overheating protection, Over/ Under voltage protection
EMC:	According to EN61000-6-3/2, EN61000-3-2/3
Approvals:	CCC, CE
Amb.Temp:	-25~+60°C
Insulation class:	F

材料:	风轮-ABS; 转子-镀黑; 电气罩-压铸铝
从引出线端看为:	逆时针
电机防护等级:	IP54
安装位置:	竖直、水平线2个方向
连续工作制:	(S1)
轴承:	免维护轴承
电气特性:	控制信号输入: 0~10V DC/PWM; 含主动式PFC电路; 集成PID调节; 速度反馈信号; 报警信号继电器 单路辅助电源: 10V DC±10%, max.10mA
保护:	限流、堵转、软启动、缺相故障、过温保护、过/欠压保护
EMC:	符合EN61000-6-3/2, EN61000-3-2/3
证书:	CCC、CE认证
环境温度:	-25~+60°C
绝缘等级:	F

Ø 450 EC BACKWARD CENTRIFUGAL FAN EC 外转子后倾离心风机

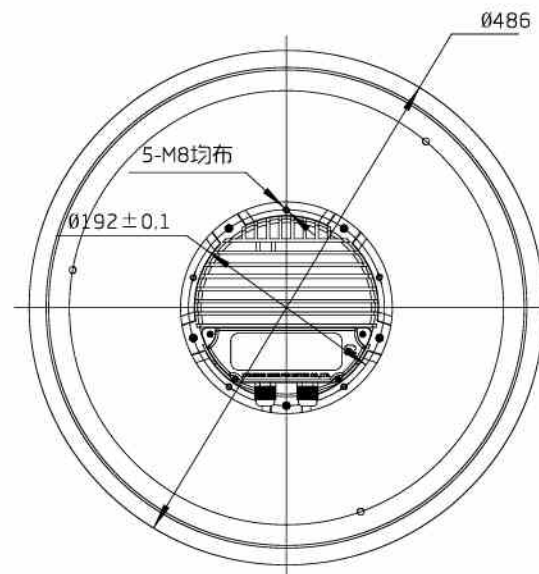
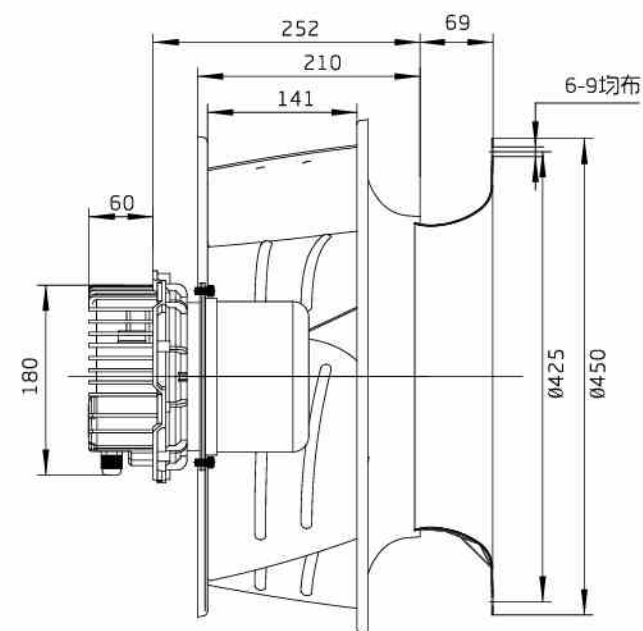
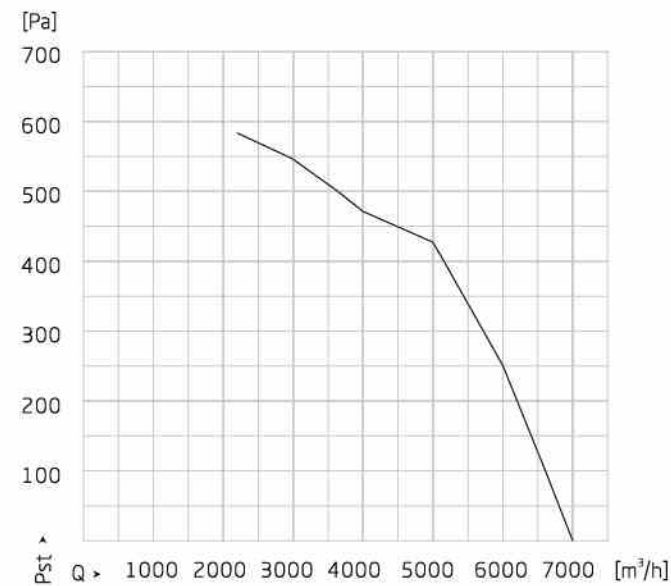

型号	电压	频率	功率	风量	电流	转速	噪音
MODEL	Voltage	Frequency	Power	Airflow	Current	RPM	Noise
	V	Hz	W	m³/h	A	r/min	dB(A)
PMSWF112L60P10-B450X210	3~400	50/60	650	7100	1.3	1600	78

Material:	Impeller: ABS; Rotor: Coated in black; Electronics enclosure: Die-cast aluminum
Direction of rotation:	Counter clockwise, view from end cover
Type of protection:	IP54
Mounting position:	Horizontal or Vertical
Operation Mode:	S1
Bearings:	Maintenance-free ball bearings
Technical features:	Control input 0~10V DC/PWM; PFC (active); Integrated PID controller; Speed signal feedback ; Relay Single auxiliary output power supply: 10V DC±10%, max.10mA
Protection:	Current limitation, Stall protection, Soft start protection, Open phase protection, Overheating protection, Over/ Under voltage protection
EMC:	According to EN61000-6-3/2, EN61000-3-2/3
Approvals:	CCC, CE
Amb.Temp:	-25~+60°C
Insulation class:	F

材料:	风轮-ABS; 转子-镀黑; 电气罩-压铸铝
从引出线端看为:	逆时针
电机防护等级:	IP54
安装位置:	竖直、水平线2个方向
连续工作制:	(S1)
轴承:	免维护轴承
电气特性:	控制信号输入: 0~10V DC/PWM; 含主动式PFC电路; 集成PID调节; 速度反馈信号; 报警信号继电器 单路辅助电源: 10V DC±10%, max.10mA
保护:	限流、堵转、软启动、缺相故障、过温保护、过/欠压保护
EMC:	符合EN61000-6-3/2, EN61000-3-2/3
证书:	CCC、CE认证
环境温度:	-25~+60°C
绝缘等级:	F

MaEr Fan Motor

Professional · Honest · Human Oriented

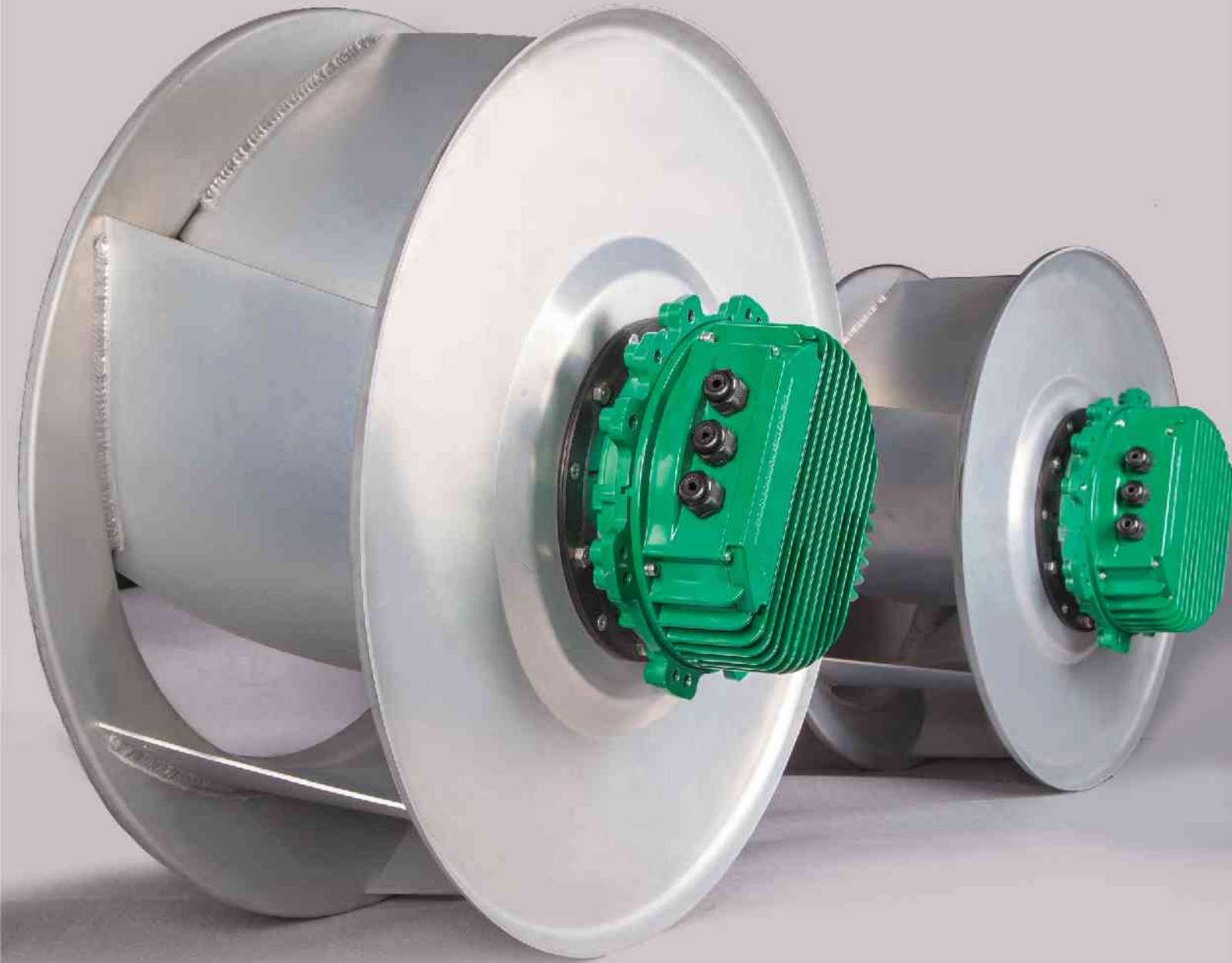

EC BACKWARD CENTRIFUGAL FAN
EC外转子后倾离心风机系列

3-400V EC150电机

MaEr Fan Motor

Professional · Honest · Human Oriented



150-400V SERIES MOTOR WIRING INSTRUCTION 150电机系列接线说明图

Wiring indication 接线标识图

P3												P2			P1			
RSA	RSB	RSA	RSB	GND	Ain1 U	4~20mA	20V	10V	Din1	GND	FG	NO	COM	NC	L3	L2	L1	PE

Portal function 接线端口功能说明图

序号	信号	分配/功能	序号	信号	分配/功能
	L3	交流电接入, 供给电压3~380-480VAC;频率50/60Hz	RSA		RS485总线连接; RSA;MODBUS通讯协议RTU方式
P1	L2	交流电接入, 供给电压3~380-480VAC;频率50/60Hz	RSB		RS485总线连接; RSB;MODBUS通讯协议RTU方式
	L1	交流电接入, 供给电压3~380-480VAC;频率50/60Hz	GND		接口P3控制信号地
PE	PE	接地线, PE连接	Ain1 U		控制输入0~10VDC/PWM
	NO	状态继电器, 浮动状态触点; 常开; 关闭错误	4~20mA		控制输入 4~20mA
P2	COM	状态继电器, 公共连接; 连接等级250VAC/2A	20V		固定电压输出20VDC (±10%最大.50mA)
	NC	状态继电器, 常闭, 解除错误	10V		固定电压输出10VDC (±10%最大.10mA)
			Din1		数字式输入端1电子设备的接通
					接通: 管脚为开路或者所施加的电压为5到50VDC;
					截止: 接地桥接或者所施加的电压<1VDC.
			FG		速度反馈信号

HUB	Portal	Description/Function	HUB	Portal	Description/Function
	L3	AC power in, voltage input 3~380-480V;50/60Hz	RSA		Bus RS485; RSA; MODBUS RTU
P1	L2	AC power in, voltage input 3~380-480V;50/60Hz	RSB		Bus RS485; RSB; MODBUS RTU
	L1	AC power in, voltage input 3~380-480V;50/60Hz	GND		Interface P3 for signal control, ground
PE	PE	Protect earthing, ground	Ain1 U		Analogue input 1(set value) 0~10V DC/PWM
	NO	Status relay, alterable state contact; normally turn-on; turn-off when error	4~20mA		Analogue Control input 4~20mA
			20V		Rated voltage output 20VDC (±10% max. 50mA)
			10V		Rated voltage output 10VDC (±10% max. 10mA)
P2	COM	State relay, universal connectivity; contact rating 250V AC/2A			Connection of Digital input 1 enabling of electronics
	NC	State relay, normally turn-off ,turn-on when error	Din1		enabling: oping pin or applied voltage 5-50V DC;
					disabling: bridge to GND or applied voltage<1V DC
			FG		Speed Signal Feedback(Fault Feedback)

MaEr Fan Motor

Professional · Honest · Human Oriented



MaEr Fan Motor

Professional · Honest · Human Oriented



Ø 500 EC BACKWARD CENTRIFUGAL FAN EC 外转子后倾离心风机

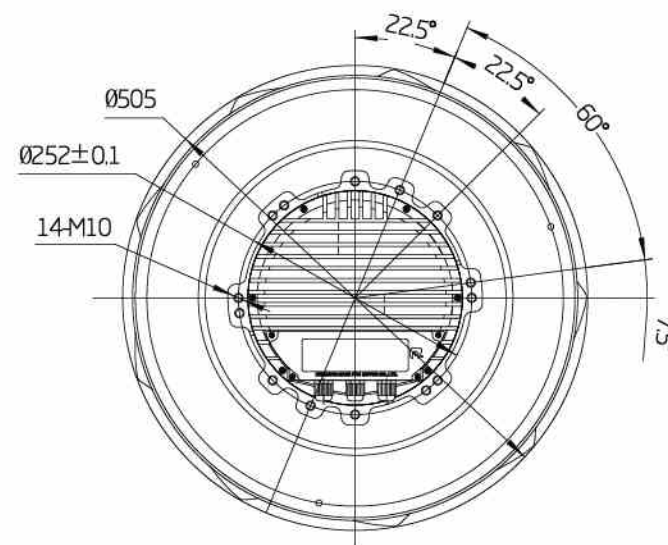
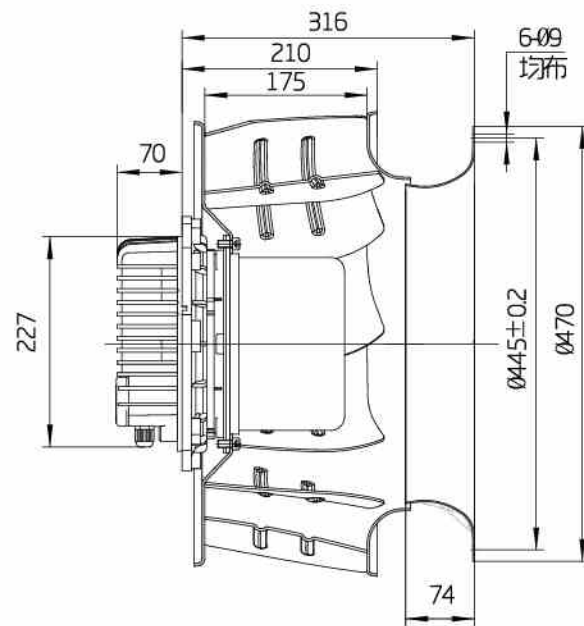
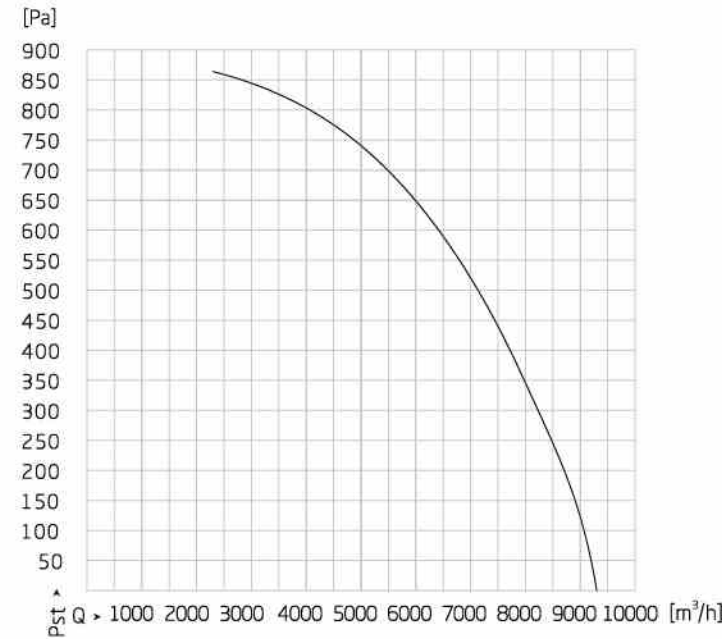

型号	电压	频率	功率	风量	电流	转速	噪音
MODEL	Voltage	Frequency	Power	Airflow	Current	RPM	Noise
	V	Hz	W	m³/h	A	r/min	dB(A)
PMSWF150L50P10-B500X230	3~400	50/60	1500	9300	2.8	1650	75

Material:	Impeller: ABS; Rotor: Coated in black; Electronics enclosure: Die-cast aluminum
Direction of rotation:	Counter clockwise, view from end cover
Type of protection:	IP54
Mounting position:	Horizontal or Vertical
Operation Mode:	S1
Bearings:	Maintenance-free ball bearings
Technical features:	Control input: 0~10V DC/PWM; Current input control: 4-20mA; Integrated PID controller; Speed signal feedback; relay Dual auxiliary output power supplies: 10V DC±10%, max.10mA; 20V DC±10%, max.50mA
Protection:	Current limitation, Stall protection, Soft start protection, Open phase protection, Overheating protection, Over/ Under voltage protection
EMC:	According to EN61000-6-3/2, EN61000-3-2/3
Approvals:	CCC, CE
Amb.Temp:	-40~+65°C
Insulation class:	F
材料:	风轮-ABS; 转子-镀黑; 电气罩-压铸铝
从引出线端看为:	逆时针
电机防护等级:	IP54
安装位置:	竖直、水平线2个方向
连续工作制:	(S1)
轴承:	免维护轴承
电气特性:	控制信号输入: 0~10V DC/PWM; 电流控制: 4-20mA; 集成PID调节; 速度反馈信号; 报警信号继电器 双路辅助电源: 10V DC±10%, max.10mA; 20V DC±10%, max.50mA
保护:	限流、堵转、软启动、缺相故障、过温保护、过/欠压保护
EMC:	符合EN61000-6-3/2, EN61000-3-2/3
证书:	CCC、CE认证
环境温度:	-40~+65°C
绝缘等级:	F

MaEr Fan Motor

Professional · Honest · Human Oriented



MaEr Fan Motor

Professional · Honest · Human Oriented



Ø 560 EC BACKWARD CENTRIFUGAL FAN EC 外转子后倾离心风机

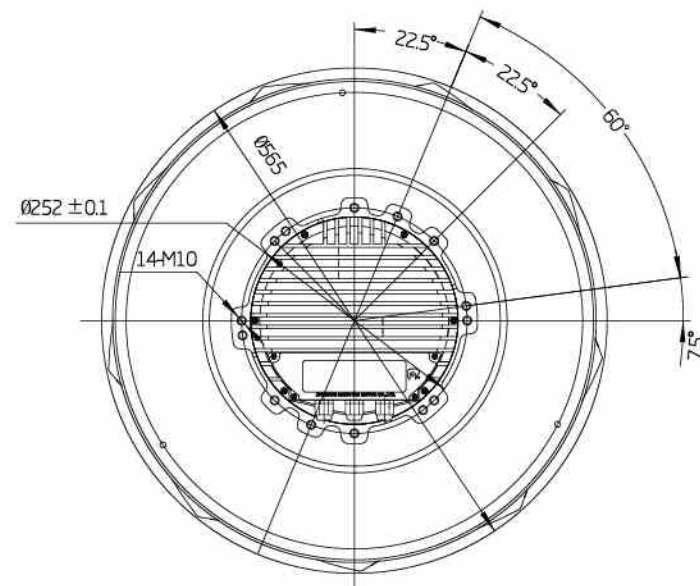
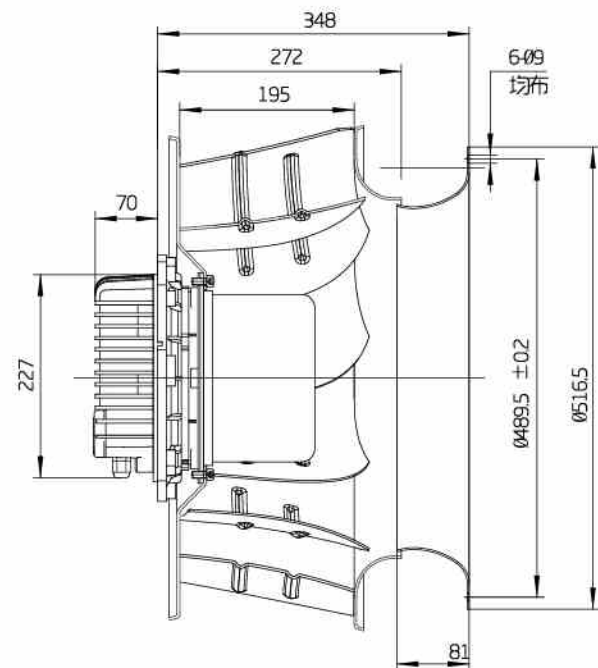
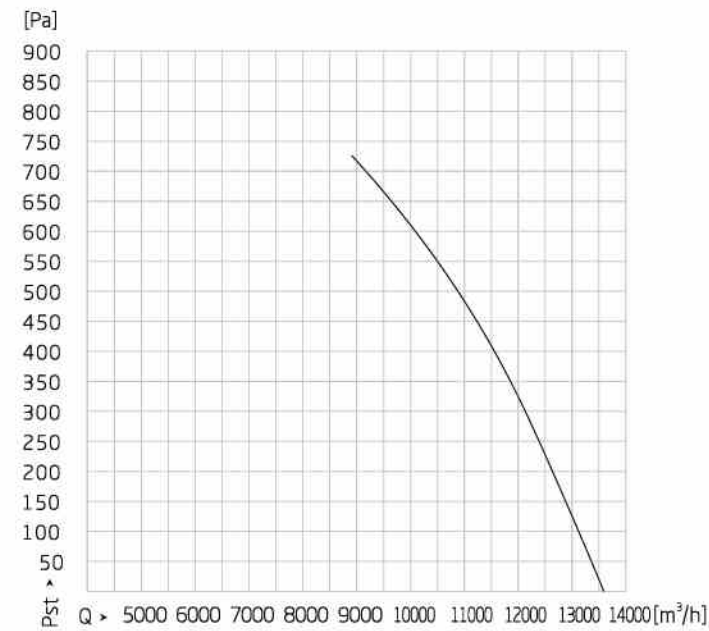

型号	电压	频率	功率	风量	电流	转速	噪音
MODEL	Voltage	Frequency	Power	Airflow	Current	RPM	Noise
	V	Hz	W	m³/h	A	r/min	dB(A)
PMSWF150L85P10-B560X260	3~400	50/60	1900	13500	3.2	1500	81

Material:	Impeller: ABS; Rotor: Coated in black; Electronics enclosure: Die-cast aluminum
Direction of rotation:	Counter clockwise, view from end cover
Type of protection:	IP54
Mounting position:	Horizontal or Vertical
Operation Mode:	S1
Bearings:	Maintenance-free ball bearings
Technical features:	Control input: 0~10V DC/PWM; Current input control: 4-20mA; Integrated PID controller; Speed signal feedback; relay Dual auxiliary output power supplies: 10V DC±10%, max.10mA; 20V DC±10%, max.50mA
Protection:	Current limitation, Stall protection, Soft start protection, Open phase protection, Overheating protection, Over/ Under voltage protection
EMC:	According to EN61000-6-3/2, EN61000-3-2/3
Approvals:	CCC, CE
Amb.Temp:	-40~+65°C
Insulation class:	F
材料:	风轮-ABS; 转子-镀黑; 电气罩-压铸铝
从引出线端看为:	逆时针
电机防护等级:	IP54
安装位置:	竖直、水平线2个方向
连续工作制:	(S1)
轴承:	免维护轴承
电气特性:	控制信号输入: 0~10V DC/PWM; 电流控制: 4-20mA; 集成PID调节; 速度反馈信号; 报警信号继电器 双路辅助电源: 10V DC±10%, max.10mA; 20V DC±10%, max.50mA
保护:	限流、堵转、软启动、缺相故障、过温保护、过/欠压保护
EMC:	符合EN61000-6-3/2, EN61000-3-2/3
证书:	CCC、CE认证
环境温度:	-40~+65°C
绝缘等级:	F

MaEr Fan Motor

Professional · Honest · Human Oriented



MaEr Fan Motor

Professional · Honest · Human Oriented



Ø 630 EC BACKWARD CENTRIFUGAL FAN EC 外转子后倾离心风机

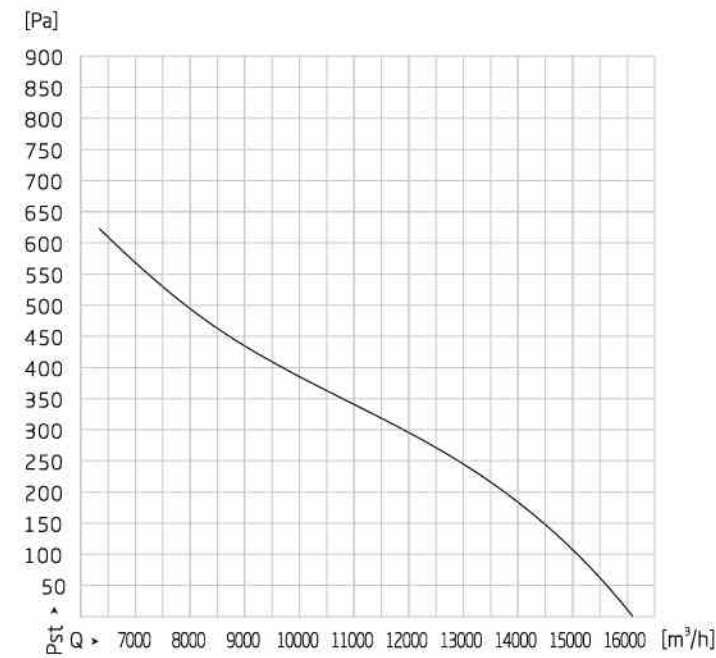

型号	电压	频率	功率	风量	电流	转速	噪音
MODEL	Voltage	Frequency	Power	Airflow	Current	RPM	Noise
	V	Hz	W	m³/h	A	r/min	dB(A)
PMSWF150L85P10-B630X290	3~400	50/60	1800	16100	3.3	1200	80

Material:	Impeller: ABS; Rotor: Coated in black; Electronics enclosure: Die-cast aluminum
Direction of rotation:	Counter clockwise, view from end cover
Type of protection:	IP54
Mounting position:	Horizontal or Vertical
Operation Mode:	S1
Bearings:	Maintenance-free ball bearings
Technical features:	Control input: 0~10V DC/PWM; Current input control: 4-20mA; Integrated PID controller; Speed signal feedback; relay Dual auxiliary output power supplies: 10V DC±10%, max.10mA; 20V DC±10%, max.50mA
Protection:	Current limitation, Stall protection, Soft start protection, Open phase protection, Overheating protection, Over/ Under voltage protection
EMC:	According to EN61000-6-3/2, EN61000-3-2/3
Approvals:	CCC, CE
Amb.Temp:	-40~+65°C
Insulation class:	F
材料:	风轮-ABS; 转子-镀黑; 电气罩-压铸铝
从引出线端看为:	逆时针
电机防护等级:	IP54
安装位置:	竖直、水平线2个方向
连续工作制:	(S1)
轴承:	免维护轴承
电气特性:	控制信号输入: 0~10V DC/PWM; 电流控制: 4-20mA; 集成PID调节; 速度反馈信号; 报警信号继电器 双路辅助电源: 10V DC±10%, max.10mA; 20V DC±10%, max.50mA
保护:	限流、堵转、软启动、缺相故障、过温保护、过/欠压保护
EMC:	符合EN61000-6-3/2, EN61000-3-2/3
证书:	CCC、CE认证
环境温度:	-40~+65°C
绝缘等级:	F

